

Operation, Repair, Parts



T-Max™ 506/657/6912 Texture Sprayer

3A6748B

EN

For portable spraying of water-based materials. Can be used for application of solvent-based materials only when solvent compatible seals are installed and solvent compatible, conductive hoses are used. For professional use only.

Not approved for use in European explosive atmosphere locations.

T-Max 506: 50 bar (5 MPa, 725 psi) Maximum Working Pressure

T-Max 657: 65 bar (6.5 MPa, 940 psi) Maximum Working Pressure

T-Max 6912: 69 bar (6.9 MPa, 1000 psi) Maximum Working Pressure

See page 4-6 for model information.



Important Safety Instructions

Read all warnings and instructions in this manual and related manuals before using the equipment. Be familiar with the controls and the proper usage of the equipment. Save these instructions.

Related Manuals

STX Trigger Gun	3A6746	Bag Roller Kits	312790, 3A4995
T-Max Remote Switch Kit	3A6784	T-Max Applicator	312879
PrimeValve Accessory Kit	3A6785	Free Flow Applicator	313537
Vibra-Flo T-Max	3A6909	Inline Applicator	309495
Air Manifold Kit	3A6839		



t35550a



PROVEN QUALITY. LEADING TECHNOLOGY.



Contents



Models	4
Warnings	7
Component Identification 506	11
Component Identification 657	12
Component Identification 6912	13
Component Identification	14
Pump Control Settings	15
T-Max 506/657	15
T-Max 6912	15
Operation	15
Preparation	16
Grounding	16
Solvent-Based Materials	16
Amp Switch	16
Extension Cords	17
Mixing Material	17
Hose Lubrication Mixing Instructions	18
Pressure Relief Procedure	19
Setup	21
Start Up - Airless	24
Spray Tip Installation	26
Clear Spray Tip Clog	27
Start Up - Air Assist	28
Start Up - Air Assist STX Gun	30
Operation	32
Cleanup	33
Troubleshooting	39
Repair	43
Control Board Diagnostics	43
Control Board Removal 506/657	45
Control Board Installation 506, 657	47
Control Board Removal 6912	49
Control Board Installation 6912	51
Pump Removal	54
Pump Installation	56
Pump Repair 506/657	58
Pump Repair 6912	60
Cross-Section Reference / Pump Ball Identification 6912	63
Motor Removal	64
Motor Installation	65
Recycling and Disposal at End of Life	66

Parts - Hopper Frame	68
Parts List - Frame	69
Parts - Power Module 506/657	70
Parts List - Power Module 506/657	71
Parts - Power Module 6912	72
Parts List - Power Module 6912	73
Parts - Pump 289555 (506)	74
Parts List - Pump	74
Parts - Pump 289556 (657)	75
Parts List - Pump	75
Parts - Pump 25E668 (6912)	76
Parts List - Pump 25E668 (6912)	77
Parts - Control Box 506/657	78
Parts List - Control Box 506/657	79
Parts - Control Box 6912	80
Parts List - Control Box	80
Wiring Diagrams	81
506/657	81
6912 - US	82
6912 - UK	83
Technical Specifications	84
CALIFORNIA PROPOSITION 65	86
Graco Standard Warranty	87
Graco Information	88

Models

Models

T-MAX 506						
Model	Hoses	Applicator	17 Gallon Hopper	Power Cord	VAC	
17Z169	Bare Unit			CEE 7/7	230VAC	
17X980	3m whip 5m	T-Max Applicator	✓			
17Z170	Bare Unit			UK	110VAC	
17X982	3m whip 5m	T-Max Applicator	✓			
17Z291	Bare Unit			Multi-Cord	230VAC	
17X981	3m whip 5m	T-Max Applicator	✓			

T-MAX 657						
Model	Hoses	Applicator	17 Gallon Hopper	Power Cord	VAC	
17Z171	Bare Unit			CEE 7/7	230VAC	
17X983	3m whip 5m	T-Max Applicator	✓			
17Z172	Bare Unit			UK	110VAC	
17X985	3m whip 5m	T-Max Applicator	✓			
17Z292	Bare Unit			Multi-Cord	230VAC	
17X984	3m whip 5m	T-Max Applicator	✓			

T-MAX 6912

Model	Hoses	Applicator	25 Gallon Hopper	Air Manifold	Power Cord	VAC
17Z173	Bare Unit					
17Z626	3m whip 5m 10m		✓		CEE 7/7	230VAC
17X986	3m whip 5m 10m	T-Max Applicator	✓			
17Z532	3m whip 5m 10m	Inline Applicator	✓			
17X990	3m whip 5m 10m	Free-Flow Applicator	✓	✓		
17X993	3m whip 5m 10m	STX Spray Gun	✓	✓		
17Z285	3m whip 5m 10m	T-Max Applicator Free-Flow Applicator	✓	✓		
17Z288	3m whip 5m 10m	T-Max Applicator STX Spray Gun	✓	✓		
17Z529	3m whip 5m 10m	T-Max Applicator Pole Applicator	✓	✓		
17Z174	Bare Unit					
17Z629	3m whip 5m 10m		✓		UK	110VAC
17X988	3m whip 5m 10m	T-Max Applicator	✓			
17Z534	3m whip 5m 10m	Inline Applicator	✓			
17X992	3m whip 5m 10m	Free-Flow Applicator	✓	✓		
17Z282	3m whip 5m 10m	STX Spray Gun	✓	✓		
17Z287	3m whip 5m 10m	T-Max Applicator Free-Flow Applicator	✓	✓		
17Z290	3m whip 5m 10m	T-Max Applicator STX Spray Gun	✓	✓		
17Z531	3m whip 5m 10m	T-Max Applicator Pole Applicator	✓	✓		



Models

T-MAX 6912 continued

Model	Hoses	Applicator	25 Gallon Hopper	Air Manifold	Power Cord	VAC	
17Z293	Bare Unit				Multi-Cord	230VAC	
17Z628	3m whip 5m 10m		✓				
17X987	3m whip 5m 10m	T-Max Applicator	✓				
17Z533	3m whip 5m 10m	Inline Applicator	✓				
17X991	3m whip 5m 10m	Free-Flow Applicator	✓	✓			
17X994	3m whip 5m 10m	STX Spray Gun	✓	✓			
17Z286	3m whip 5m 10m	T-Max Applicator Free-Flow Applicator	✓	✓			
17Z289	3m whip 5m 10m	T-Max Applicator STX SPRay Gun	✓	✓			
17Z530	3m whip 5m 10m	T-Max Applicator Pole Applicator	✓	✓			
17Z175	Bare Unit						
17Z630			✓	✓			
17X989	50' 9' whip	T-Max Applicator	✓	✓			
17Z283	50' 9' whip	STX Spray Gun	✓	✓			
17Z284	100' 9' whip	STX Spray Gun	✓	✓			
17Z703	100' 9' whip	STX Spray Gun	✓	✓			

Warnings

The following warnings are for the setup, use, grounding, maintenance, and repair of this equipment. The exclamation point symbol alerts you to a general warning and the hazard symbols refer to procedure-specific risks. When these symbols appear in the body of this manual or on warning labels, refer back to these Warnings. Product-specific hazard symbols and warnings not covered in this section may appear throughout the body of this manual where applicable.

WARNING



GROUNDING

This product must be grounded. In the event of an electrical short circuit, grounding reduces the risk of electric shock by providing an escape wire for the electric current. This product is equipped with a cord having a grounding wire with an appropriate grounding plug. The plug must be plugged into an outlet that is properly installed and grounded in accordance with all local codes and ordinances.

- Improper installation of the grounding plug is able to result in a risk of electric shock.
- When repair or replacement of the cord or plug is required, do not connect the grounding wire to either flat blade terminal.
- The wire with insulation having an outer surface that is green with or without yellow stripes is the grounding wire.
- Check with a qualified electrician or serviceman when the grounding instructions are not completely understood, or when in doubt as to whether the product is properly grounded.
- Do not modify the plug provided; if it does not fit the outlet, have the proper outlet installed by a qualified electrician.
- This product is for use on a nominal 110V or 230V circuit and has a grounding plug similar to the plugs illustrated in the figure below.

110V UK

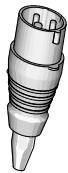

120V

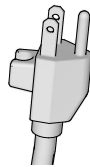

230V

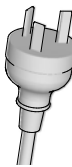
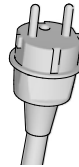

ti24583a

- Only connect the product to an outlet having the same configuration as the plug.
- Do not use an adapter with this product.

Extension Cords:

- Use only a 3-wire extension cord that has a grounding plug and a grounding receptacle that accepts the plug on the product.
- Make sure your extension cord is not damaged. If an extension cord is necessary use 12 AWG (2.5mm) minimum to carry the current that the product draws.
- An undersized cord results in a drop in line voltage and loss of power and overheating.

WARNING



FIRE AND EXPLOSION HAZARD

Flammable fumes, such as solvent and material fumes, in work area can ignite or explode. To help prevent fire and explosion:



- Do not spray flammable or combustible materials near an open flame or sources of ignition such as cigarettes, motors, and electrical equipment.



- Material or solvent flowing through the equipment is able to result in static electricity. Static electricity creates a risk of fire or explosion in the presence of material or solvent fumes. All parts of the spray system, including the pump, hose assembly, spray gun, and objects in and around the spray area shall be properly grounded to protect against static discharge and sparks. Use Graco conductive or grounded high-pressure airless material sprayer hoses.



- Verify that all containers and collection systems are grounded to prevent static discharge. Do not use pail liners unless they are anti-static or conductive.
- Connect to a grounded outlet and use grounded extensions cords. Do not use a 3-to-2 adapter.
- Do not use a material or a solvent containing halogenated hydrocarbons.
- Do not spray flammable or combustible liquids in a confined area.
- Keep spray area well-ventilated. Keep a good supply of fresh air moving through the area.
- Sprayer generates sparks. Keep pump assembly in a well ventilated area a least 20 feet (6.1 m) from the spray area when spraying, flushing, cleaning, or servicing. Do not spray pump assembly.
- Do not smoke in the spray area or spray where sparks or flame is present.
- Do not operate light switches, engines, or similar spark producing products in the spray area.
- Keep area clean and free of material or solvent containers, rags, and other flammable materials.
- Know the contents of the materials and solvents being sprayed. Read all Safety Data Sheets (SDSs) and container labels provided with the materials and solvents. Follow the material and solvents manufacturer's safety instructions.
- Keep a working fire extinguisher in the work area.



ELECTRIC SHOCK HAZARD

This equipment must be grounded. Improper grounding, setup, or usage of the system can cause electric shock.



- Turn off and disconnect power cord before servicing equipment.
- Connect only to grounded electrical outlets.
- Use only 3-wire extension cords.
- Ensure ground prongs are intact on power and extension cords.
- Do not expose to rain. Store indoors.
- Wait five minutes after disconnecting power cord before servicing.

WARNING
**SKIN INJECTION HAZARD**

High-pressure spray is able to inject toxins into the body and cause serious injury that can result in amputation. In the event that injection occurs, **get immediate surgical treatment**.



- Do not aim the gun at, or spray any person or animal.
- Keep hands and other body parts away from the discharge. For example, do not try to stop leaks with any part of the body.
- Always use the spray tip guard. Do not spray without spray tip guard in place.
- Use Graco spray tips.
- Use caution when cleaning and changing spray tips. In the case where the spray tip clogs while spraying, follow the **Pressure Relief Procedure** for turning off the unit and relieving the pressure before removing the spray tip to clean.
- Equipment maintains pressure after power is shut off. Do not leave the equipment energized or under pressure while unattended. Follow the **Pressure Relief Procedure** when the equipment is unattended or not in use, and before servicing, cleaning, or removing parts.
- Check hoses and parts for signs of damage. Replace any damaged hoses or parts.
- This system is capable of producing 1000 psi (69 bar, 6.9 MPa). Use Graco parts or accessories that are rated a minimum of 1000 psi (69 bar, 6.9 MPa).
- Verify that all connections are secure before operating the unit.
- Know how to stop the unit and bleed pressure quickly. Be thoroughly familiar with the controls.

**PRESSURIZED ALUMINUM PARTS HAZARD**

Use of fluids that are incompatible with aluminum in pressurized equipment can cause serious chemical reaction and equipment rupture. Failure to follow this warning can result in death, serious injury, or property damage.

- Do not use 1,1,1-trichloroethane, methylene chloride, other halogenated hydrocarbon solvents or fluids containing such solvents.
- Do not use chlorine bleach.
- Many other fluids may contain chemicals that can react with aluminum. Contact your material supplier for compatibility.

WARNING



EQUIPMENT MISUSE HAZARD

Misuse can cause death or serious injury.

- Do not operate the unit when fatigued or under the influence of drugs or alcohol.
- Do not exceed the maximum working pressure or temperature rating of the lowest rated system component. See **Technical Specifications** in all equipment manuals.
- Use fluids and solvents that are compatible with equipment wetted parts. See **Technical Specifications** in all equipment manuals. Read fluid and solvent manufacturer's warnings. For complete information about your material, request Safety Data Sheets (SDSs) from distributor or retailer.
- Do not leave the work area while equipment is energized or under pressure.
- Turn off all equipment and follow the **Pressure Relief Procedure** when equipment is not in use.
- Check equipment daily. Repair or replace worn or damaged parts immediately with genuine manufacturer's replacement parts only.
- Do not alter or modify equipment. Alterations or modifications may void agency approvals and create safety hazards.
- Make sure all equipment is rated and approved for the environment in which you are using it.
- Use equipment only for its intended purpose. Call your distributor for information.
- Route hoses and cables away from traffic areas, sharp edges, moving parts, and hot surfaces.
- Do not kink or over bend hoses or use hoses to pull equipment.
- Keep children and animals away from work area.
- Comply with all applicable safety regulations.



MOVING PARTS HAZARD

Moving parts can pinch, cut, or amputate fingers and other body parts.

- Keep clear of moving parts.
- Do not operate equipment with protective guards or covers removed.
- Equipment can start without warning. Before checking, moving, or servicing equipment, follow the **Pressure Relief Procedure** and disconnect all power sources.



PERSONAL PROTECTIVE EQUIPMENT

Wear appropriate protective equipment when in the work area to help prevent serious injury, including eye injury, hearing loss, inhalation of toxic fumes, and burns. This protective equipment includes but is not limited to:

- Protective eyewear, and hearing protection.
- Respirators, protective clothing, and gloves as recommended by the fluid and solvent manufacturer.

Component Identification 506

Component Identification 506

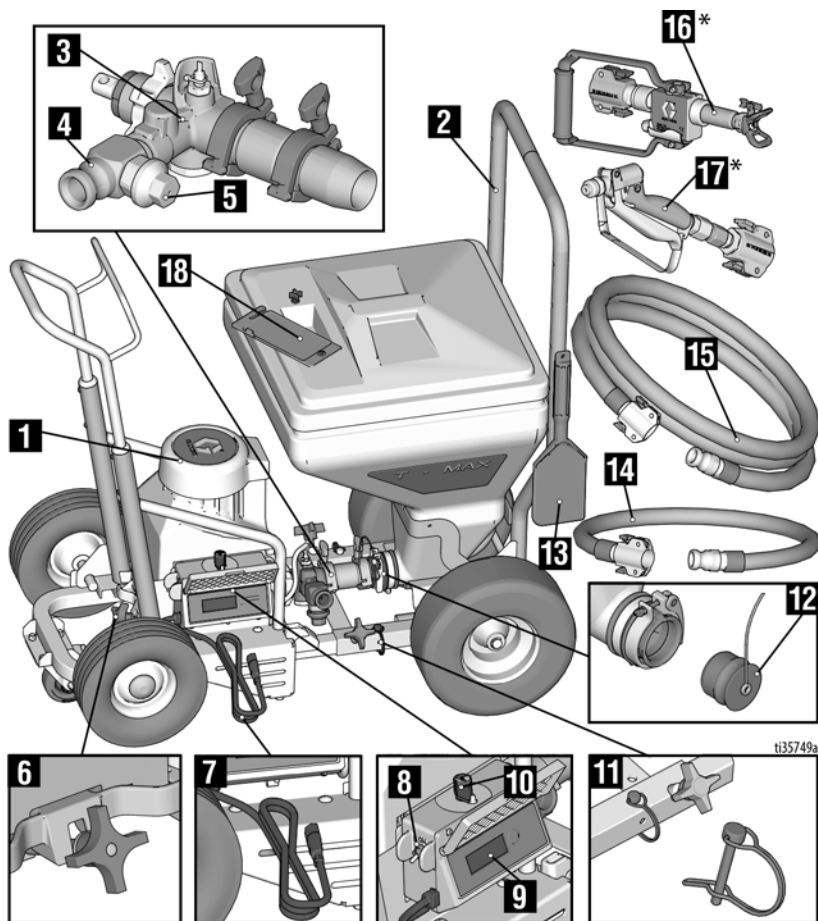

tt35749a

1	Pump Module
2	Hopper Frame
3	Pump
4	Pump Outlet
5	Pressure Relief Valve
6	Module Securing Clamp
7	Power Cord
8	ON/OFF Switch
9	Display
10	Pressure Control Knob
11	Locking Pin

12	Hopper Plug
13	Scraper Tool
14	Whip Hose
15	Material Hose
16	T-Max Applicator
17	Inline Applicator
18	Tool Box

NOTE: All hoses sent with the unit are for water-based material application only.

* See page 14 for all applicators.

Component Identification 657

Component Identification 657

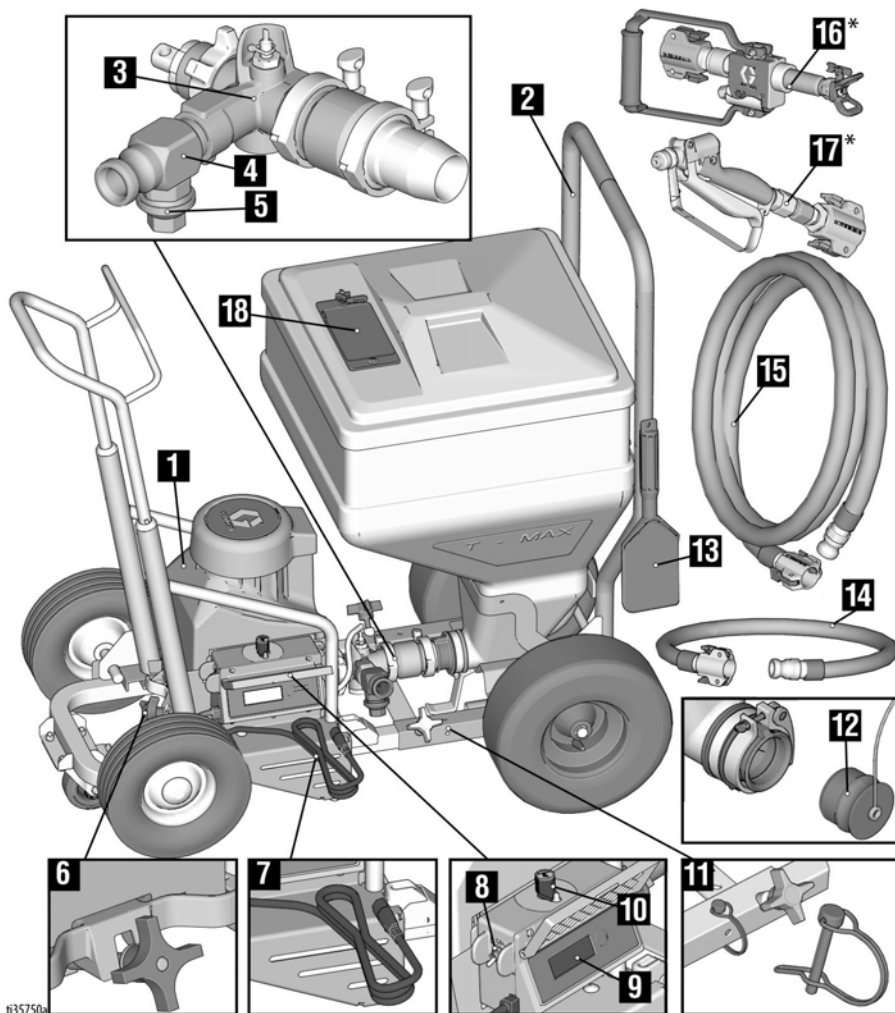

ti35750a

1	Pump Module
2	Hopper Frame
3	Pump
4	Pump Outlet
5	Pressure Relief Valve
6	Module Securing Clamp
7	Power Cord
8	ON/OFF Switch
9	Display
10	Pressure Control Knob
11	Locking Pins

12	Hopper Plug
13	Scraper Tool
14	Whip Hose
15	Material Hose
16	T-Max Applicator
17	Inline Gun
18	Tool Box

NOTE: All hoses sent with the unit are for water-based material application only.

* See page14 for all applicators.

Component Identification 6912

Component Identification 6912

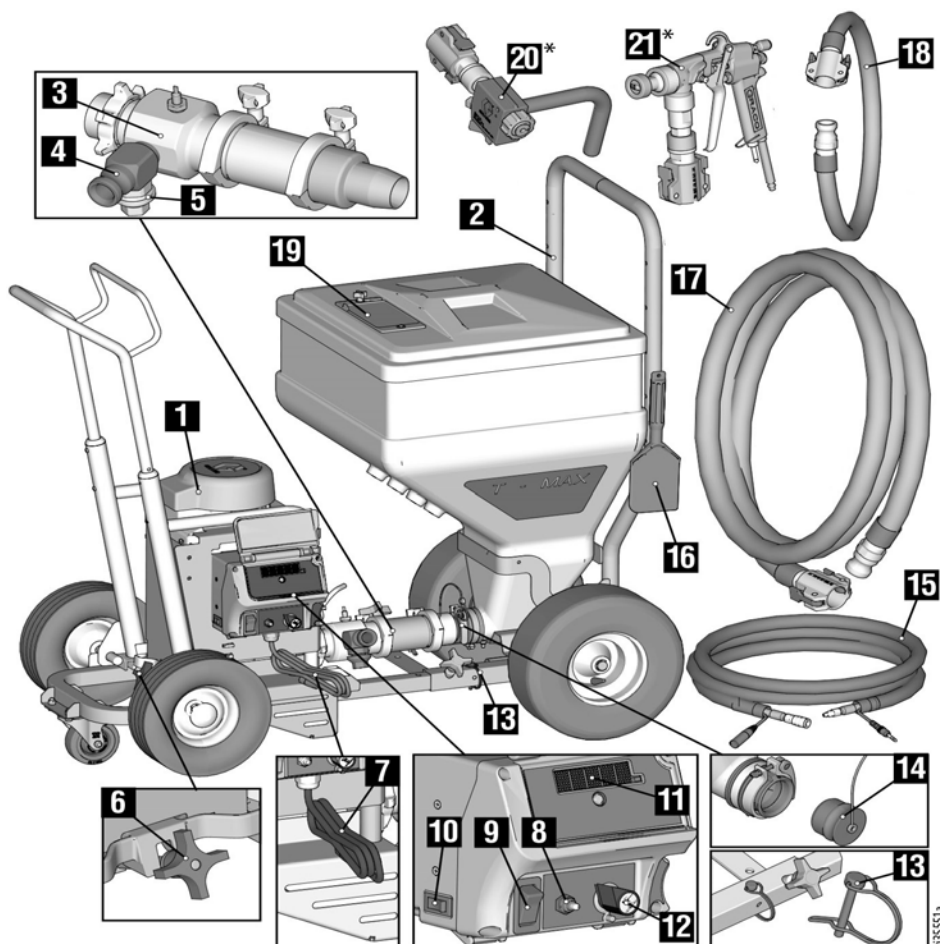

1	Pump Module
2	Hopper Frame
3	Pump
4	Pump Outlet
5	Pressure Relief Valve
6	Module Securing Clamp
7	Power Cord
8	Pump Mode Switch
9	ON/OFF Switch
10	Amp Switch
11	Display
12	Pressure Control Knob
13	Locking Pins

14	Hopper Plug
15	Signal / Air Hose
16	Scraper Tool
17	Material Hose
18	Whip Hose
20	Free Flow Applicator
21	STX Spray Gun

NOTE: All hoses sent with the unit are for water-based material application only.

* See page 14 for all applicators.

Component Identification

Component Identification

**Free Flow
Applicator (17Z128)**

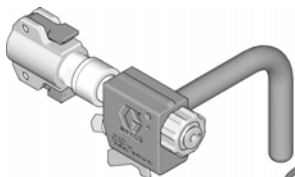

**18m Remote
Switch (17Z157)**



**30m Remote
Switch (17Z158)**

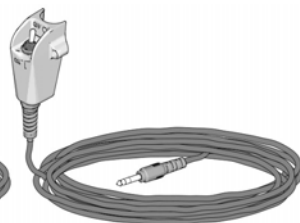

**T-Max Applicator
(17Z054)**

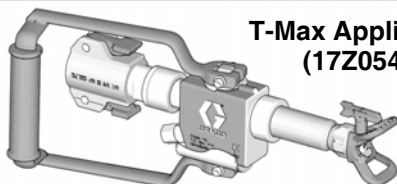

**STX Spray Gun
(17Y910)**

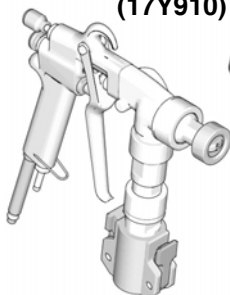

**13m Signal/Air
Hose (17Z144)**

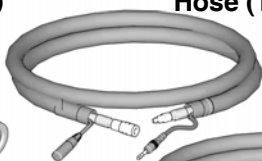

**18m Signal/Air
Hose (17Z148)**

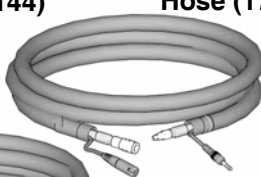

**33m Signal/Air
Hose (17Z151)**

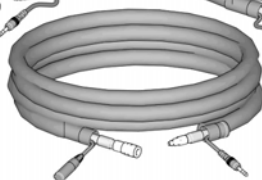

**Inline Applicator
(17Y907)**

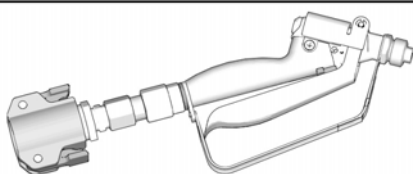

1135552a

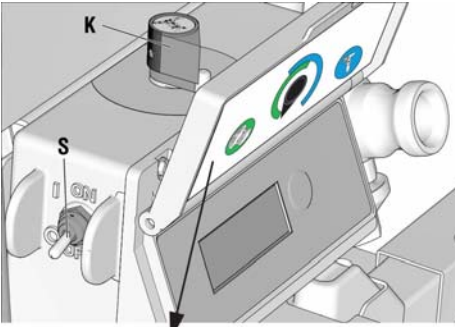

Pump Control Settings

T-Max 506/657



Flow Mode (first half of Pressure Control Knob): The motor will run continuously at the speed determined by the Pressure Control Knob (K). 0-100%

Pressure Mode (second half of Pressure Control Knob): The motor will run to meet the pressure determined by the Pressure Control Knob (K).

Pump Control Setting	Description
Pressure Mode 	The motor will run to meet the pressure determined by the Pressure Control Knob (K).
Flow Mode with Remote Control 	The “Flow Mode with Remote Control” setting allows the user to control ON/OFF functionality of the pump through the remote toggle switch or the STX Spray Gun. When the remote toggle switch or the STX Spray Gun is installed and the pump control settings are set to “Flow Mode with Remote Control”, they can be used to turn the pump ON and OFF.
Flow Mode 	The motor will run continuously at the speed determined by the Pressure Control Knob (K). 0-100%

T-Max 6912

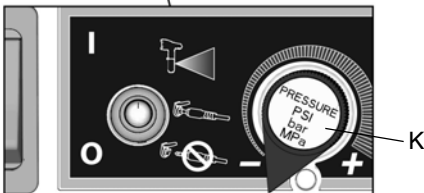
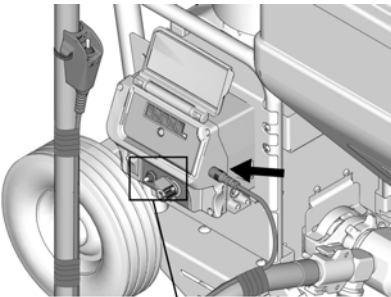

Operation

The motor power switch (S) must be ON for the sprayer to pump material.

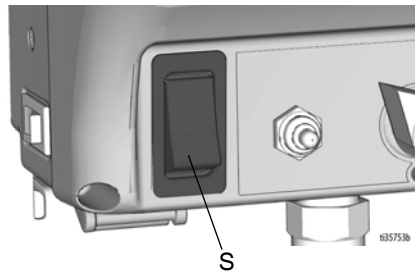

Preparation

Grounding



The equipment must be grounded to reduce the risk of static sparking and electric shock. An electric or static spark can cause fumes to ignite or explode. An improper ground can cause electric shock. A good ground provides an escape wire for the electric current.

This product is equipped with a cord having a grounding wire with an appropriate grounding plug. The plug must be plugged into an outlet that is properly installed and grounded in accordance with all local codes and ordinances.

Do not modify the plug provided; if it does not fit the outlet, have the proper outlet installed by a qualified electrician.

Solvent-Based Materials

NOTE: All hoses sent with the unit are for water-based material application only.

Solvent compatible hoses and applicators must be used.

Flush the Equipment



To avoid fire and explosion, always ground equipment and waste container. To avoid static sparking and injury from splashing, always flush at the lowest possible pressure.

- Flush before changing materials, before fluid can dry or cure in the equipment, at the end of the day, before storing, and before repairing equipment.

- Flush with a fluid that is compatible with the fluid being dispensed and the equipment wetted parts.
 - Flush at the lowest pressure possible. Check connectors for leaks and tighten as necessary.
1. Follow **Pressure Relief Procedure**, page 19.
 2. Set pump to lowest possible fluid pressure, and start pump.
 3. Hold a metal part of the gun firmly to a grounded metal pail. Trigger the gun until clean solvent dispenses.

Amp Switch

Select 15A or 20A depending on your circuit rating. 110V units require 100-120 VAC, 50/60 Hz, 15 – 20A, 1 phase

Select 10A or 16A depending on your circuit rating. 230V units require 220-240 VAC, 50/60 Hz, 10 – 16A, 1 phase

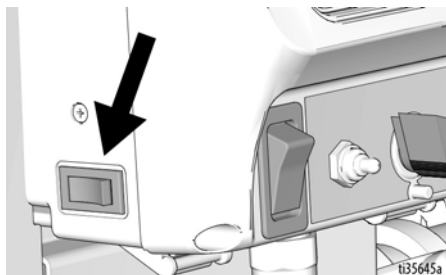

Extension Cords

Use an extension cord with an undamaged ground contact. If an extension cord is necessary, use a 3-wire, 12 AWG (2.5 mm²) minimum.

NOTE: Lighter gauge or longer extension cords may reduce sprayer performance.

Mixing Material



NOTE: Correct material mixture is essential. The pump and spray gun will not operate if the mixture is too thick. Use water-based materials only.

1. Mix the material and water in a separate container.

Dry Mix

Carefully mix texture material and water according to manufacturer instructions on bag.



Premix

Slowly add water to a 5 gallon (18.9 liter) bucket of premix.

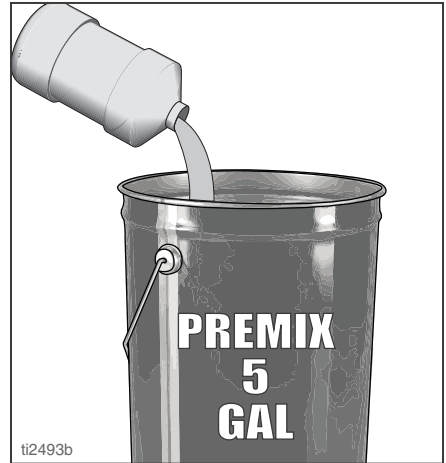

2. Agitate to mix with mixing paddle, to a smooth, lump-free consistency.



3. Make certain all dry powder clumps are mixed thoroughly before pouring mixture into the sprayer hopper.

NOTICE

Failure to make certain that all dry powder is thoroughly mixed may cause tip or pump clogging.

Preparation

Hose Lubrication Mixing Instructions

Hose lubrication (17Z224) is used to lube the pump and hose passages to reduce the risk of packout when priming aggregate material.

NOTE: If using other hose lubricants, follow manufacturer's mixing instructions.

1. Empty one bag of hose lubricant into five-gallon bucket and half fill with water.

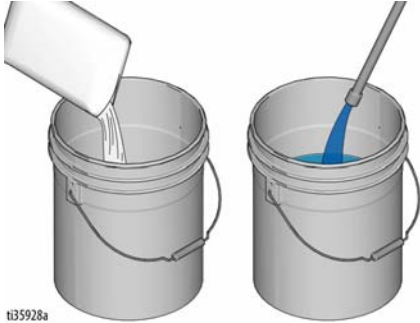

2. Stir for one minute.

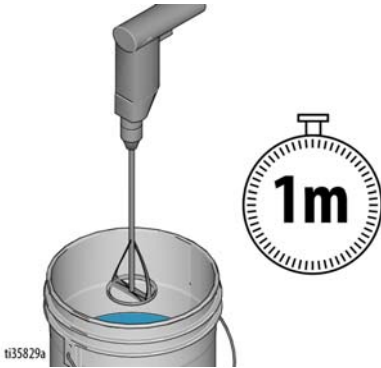

3. Fill remainder of bucket with water. Stir for one minute.

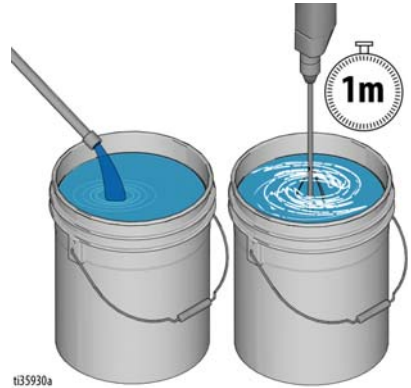

4. Let mix stand for at least five minutes or until a slick-like texture develops.

Pressure Relief Procedure



Follow the Pressure Relief Procedure whenever you see this symbol.

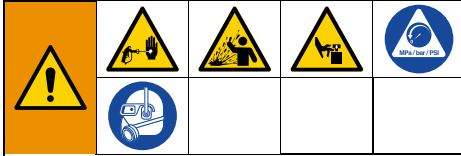

This equipment stays pressurized until pressure is manually relieved. To help prevent serious injury from pressurized fluid, such as skin injection, splashing fluid and moving parts, follow the Pressure Relief Procedure when you stop spraying and before cleaning, checking, or servicing the equipment.

1. Turn ON/OFF Switch to OFF and turn Pressure Control Knob fully counterclockwise to OFF.

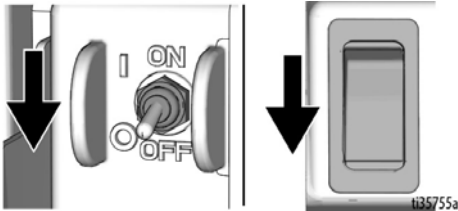

2. Point applicator into hopper. Turn applicator ON.

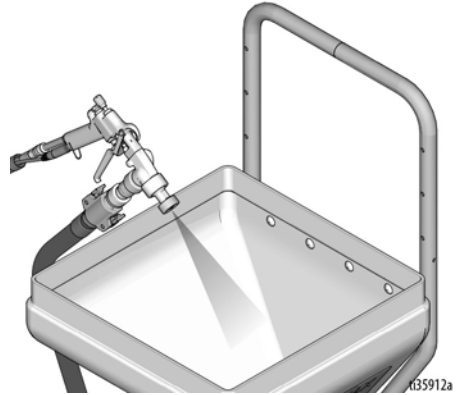
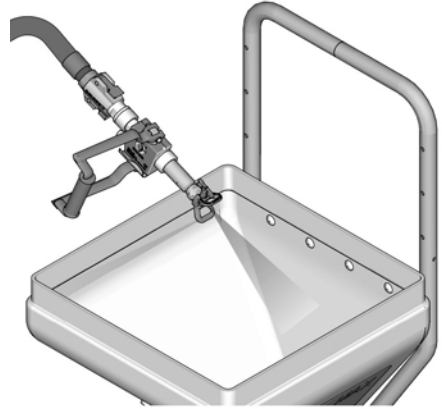

Preparation

3. If you suspect the spray tip or hose is clogged or that pressure has not been fully relieved:
 - a. If installed, turn prime valve down to prime position.
 - b. **VERY SLOWLY** loosen the retaining ring, hose end coupling, or pressure relief valve to relieve pressure gradually.

- c. Loosen the retaining nut or the coupling completely.
- d. Clear the obstruction in the hose or tip.

NOTE: If pressure relief valve was used to relieve pressure, be sure to disassemble and clean thoroughly.

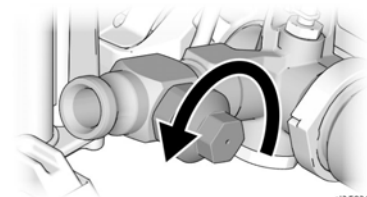
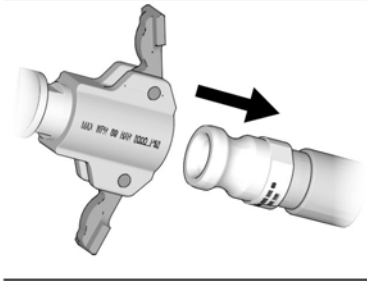
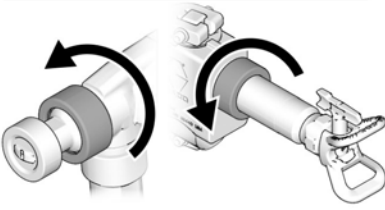
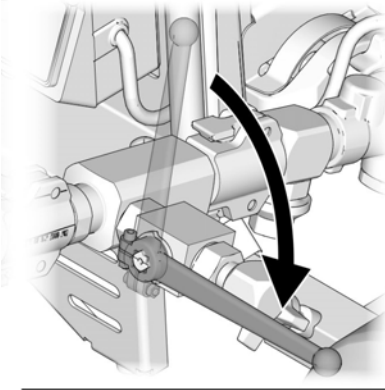

t135831a

Setup



When unpacking sprayer for the first time or after long term storage perform setup procedure. When first setup is performed remove shipping plug from fluid outlet.

1. Loosen knobs on hopper frame and pull out pins. Adjust hopper frame to fit the 506/657 (shortest frame position) or the 6912 (longest frame position).

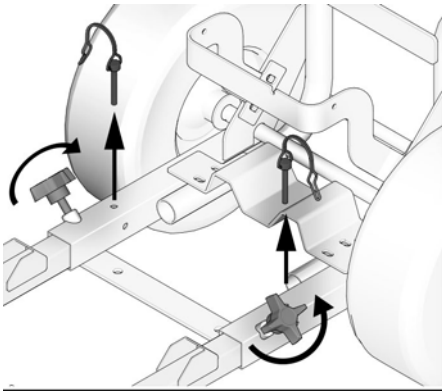

506/657

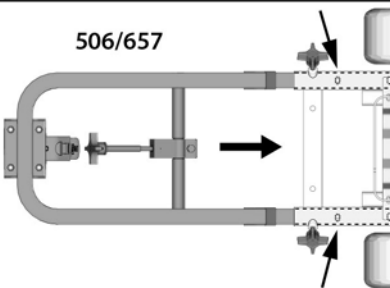

6912

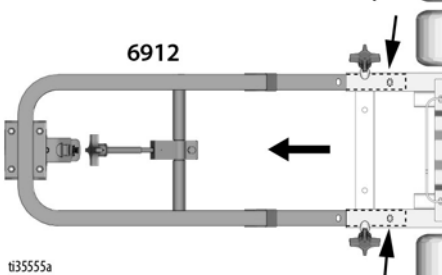

ti35555a

Depending on materials being sprayed with the T-Max 6912, different pump setups might be desired. For disassembly instructions, see **Pump Repair**, page 60.

- a. **Smooth materials:** Use steel inlet ball with spring and steel outlet ball with spring. This is how the unit is shipped.

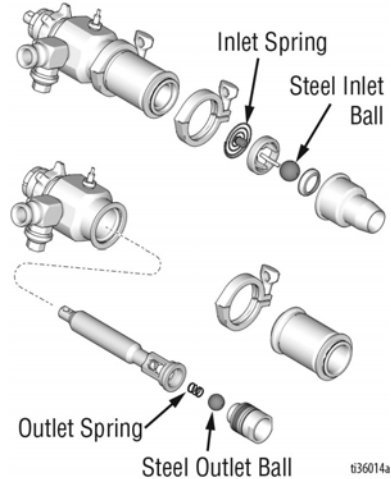

- b. **Some aggregates:** To help prevent packout, use a rubber inlet ball with spring and a steel outlet ball with spring. **NOTE:** Sometimes it is necessary to remove spring from outlet if packout occurs. See Part C.

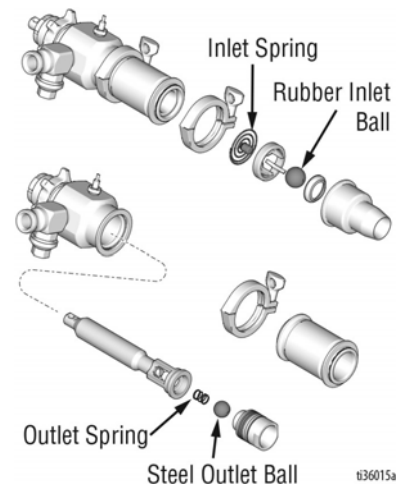

Setup

- c. To remove outlet spring, remove pump inlet and pump cylinder. Then remove spring from the piston.

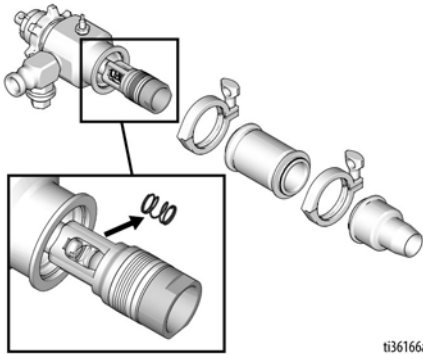

ti36166a

2. Lock front caster.

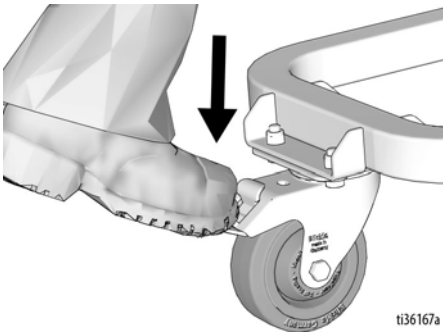

ti36167a

3. Release hopper clamp.

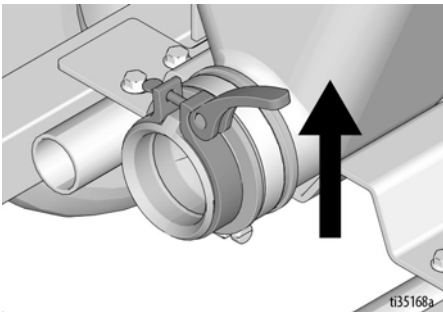

ti35168a

4. Move module securing clamp down.

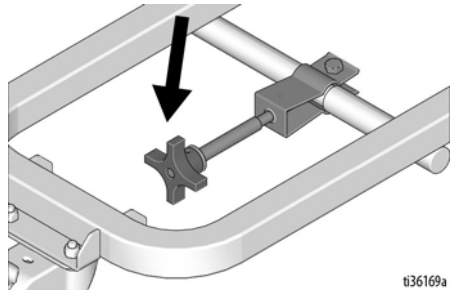

ti36169a

5. Connect pump module to hopper frame.

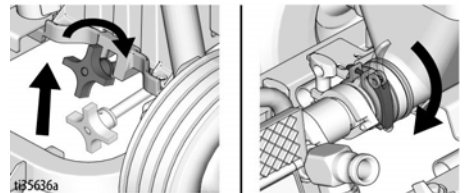
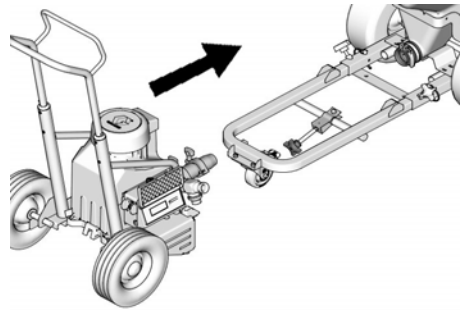

ti35636a

6. If hopper and pump do not align, loosen four nuts on back of hopper. Make sure hopper and pump are aligned and then tighten four nuts.

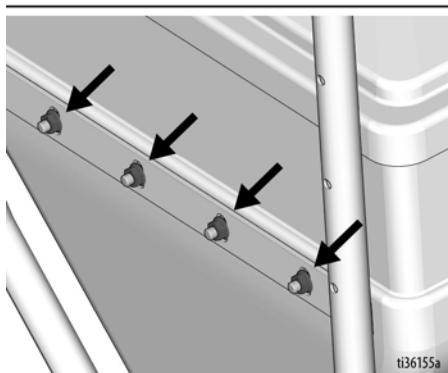
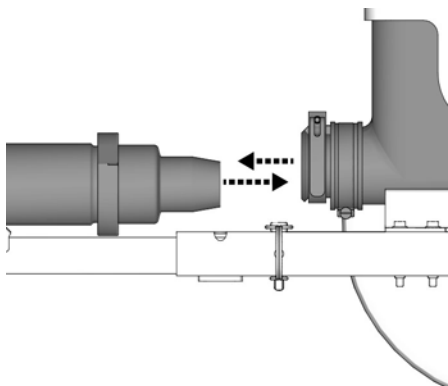

7. Turn ON/OFF Switch to OFF. Connect power cord.

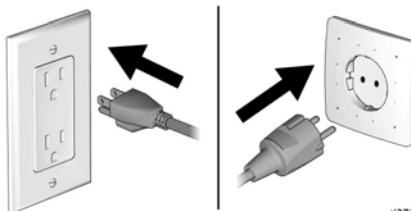
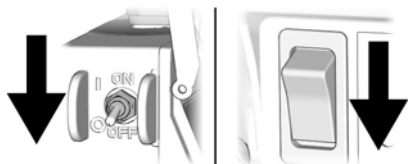

t12707b

8. Remove pump plug. Connect material hose to pump outlet.

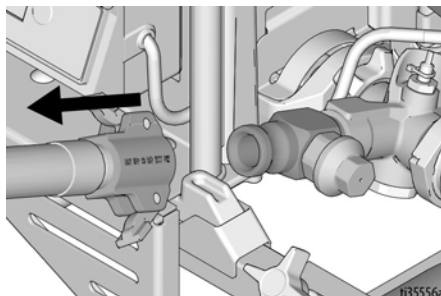

t13555a

Start Up - Airless

Start Up - Airless



Perform the start up procedure each time the sprayer is started for the first time after it has been cleaned or stored.

1. Perform **Pressure Relief Procedure**, page 19.
2. Fill material hopper with pre-mixed texture material. Bag roller sold separately.

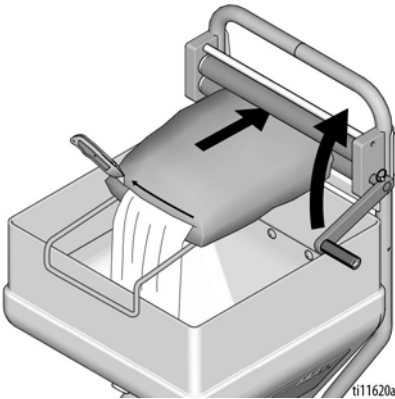

3. Prime pump.
 - a. Place material hose in hopper.

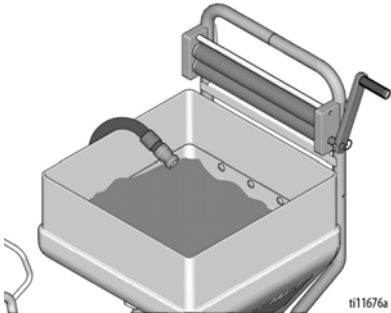

- b. Turn ON/OFF Switch to ON.

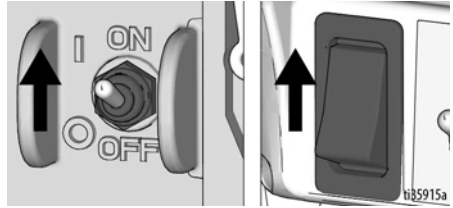

- c. **6912 only:** Place Pump Mode Switch in up position.



- d. Turn Pressure Control Knob clockwise 1/4 turn.



Start Up - Airless

- e. Once a steady stream flows from the material hose, run for an additional 30 seconds.

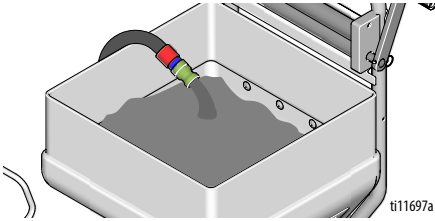

- f. Turn ON/OFF Switch to OFF.

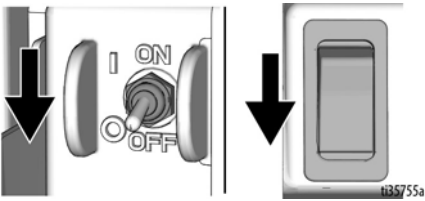

4. Install filter or air passage plug and tip extension. Material consistency and tip size will determine which filter size to use. In certain instances, air passage plug with no screen is needed with large tips to successfully spray materials with sand or rock.

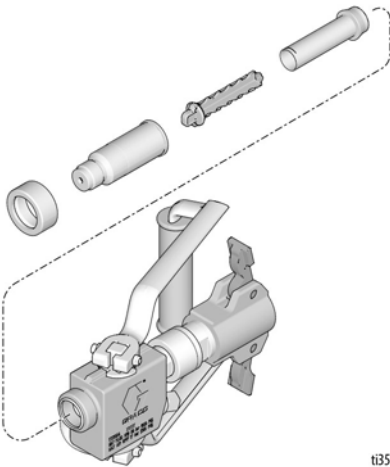

5. Connect applicator to material hose.

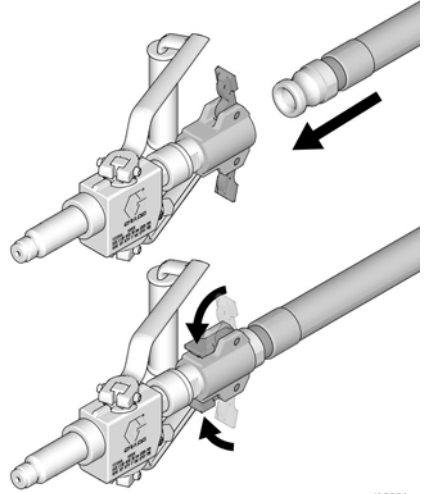

6. Turn ON/OFF Switch to ON.

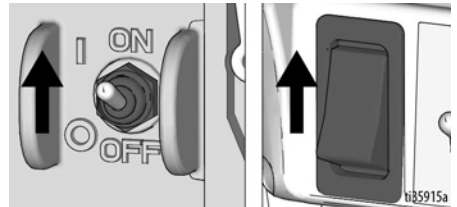

7. Turn applicator ON. Turn Pressure Control Knob clockwise until desired material delivery rate is achieved. Run for 15 seconds.

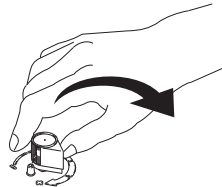

Start Up - Airless

Spray Tip Installation



To avoid serious injury from skin injection do not put your hand in front of the spray tip when installing or removing the spray tip and tip guard.

1. Perform **Pressure Relief Procedure**, page 19.
2. Verify spray tip and tip guard parts are assembled in the order shown.

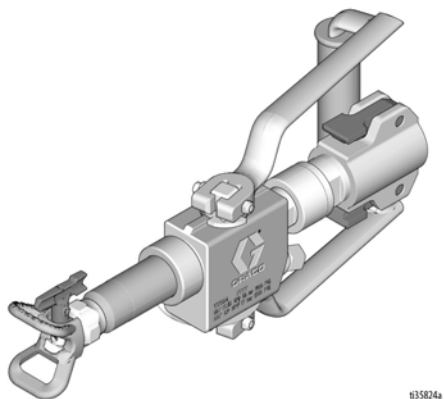

ti35824a

- a. Use spray tip to align gasket and seal in the tip guard.

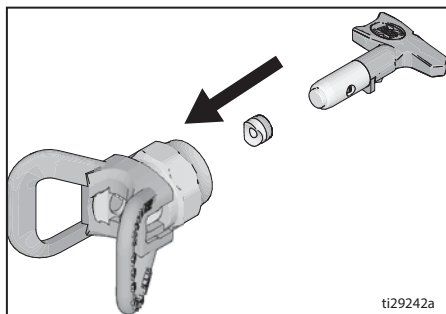

ti29242a

- b. Spray tip must be pushed all the way into the tip guard. Turn spray tip to push down.

- c. Assemble retaining ring on tip guard adapter then assemble tip guard.

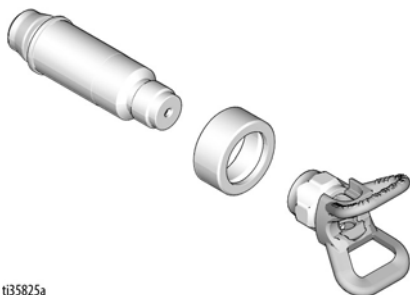

ti35825a

3. Turn the arrow shaped handle on the spray tip forward to the spray position.

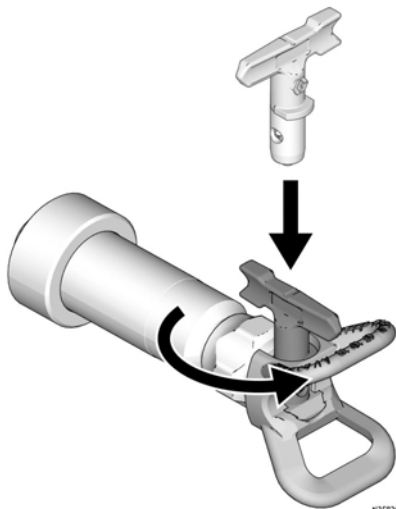

ti35826a

4. Screw spray tip and tip guard assembly onto the gun and tighten.

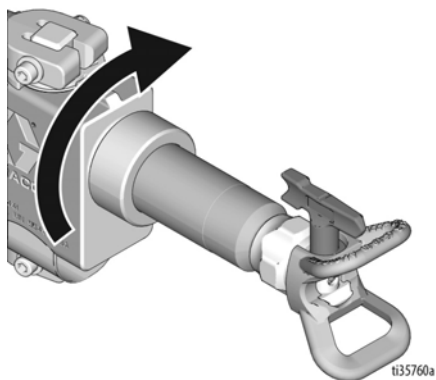

ti35760a

Clear Spray Tip Clog

To avoid tip clogs:

- When the applicator is not in use for extended periods of time, keep the tip “wet” and perform **Pressure Relief Procedure**, page 19.
 - Keep spray tip clean and free of material.
1. Rotate spray tip to unclog position. Aim applicator at floor and turn applicator ON. When clog clears, turn applicator OFF.

UNCLOG

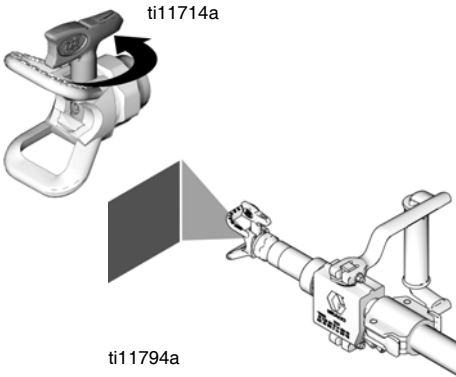

2. Rotate spray tip back to spray position. Turn applicator ON. Spray test pattern.

SPRAY

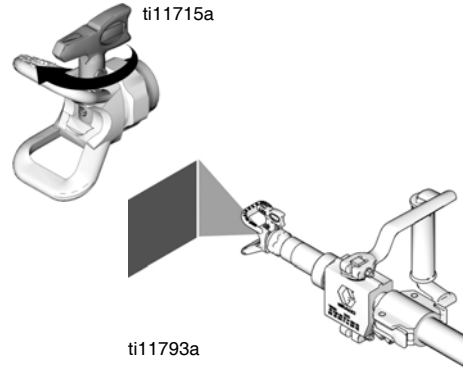

NOTE: When spraying, if the applicator is not used for a significant period of time be sure to clean the sprayer, or keep the gun “wet” by placing in water or wrapping with a wet cloth. This reduces the potential of the material drying in the gun causing pack-out of the gun.

Start Up - Air Assist

Start Up - Air Assist



Perform the start up procedure each time the sprayer is started for the first time after it has been cleaned or stored.

1. Perform **Pressure Relief Procedure**, page 19.
2. To help prevent packout, fill material hopper with hose lubrication. See **Hose Lubrication Mixing Instructions**, page 18, then follow prime instructions. Pump all hose lube through hose back into a bucket then continue with the material prime.

If spraying large aggregates, use rubber inlet ball with spring and steel outlet ball with spring.

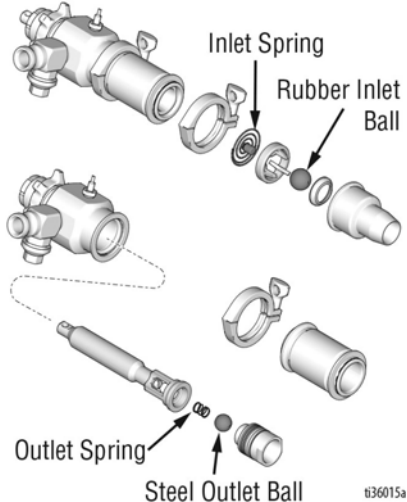

NOTE: If having packout issues in the pump, remove the outlet spring and run without it.

To prime without outlet spring, remove hose and pour water into the outlet. Place unit in "flow mode" and turn Pressure Control Knob clockwise until material comes out of the pump outlet. Turn pressure control counterclockwise until flow stops, then connect material hose. If applicable, connect a prime valve to the outlet, then connect material hose. Open prime valve and slowly turn the pressure control knob clockwise until material comes out the prime valve.

Close prime valve and allow the hose to fill (prime valve sold separately).

3. Fill hopper with mixed texture material.

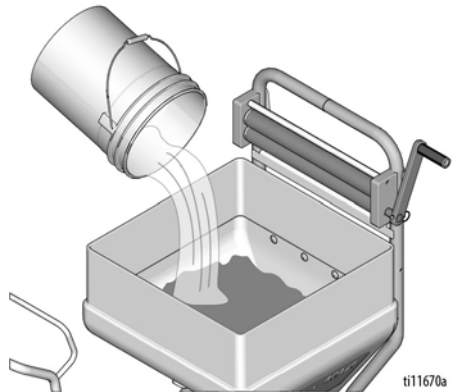

NOTE: While priming material, allow residual hose lube to flow into a bucket until material starts to come out.

Start Up - Air Assist

4. Prime pump.
 - a. Place material hose in hopper.

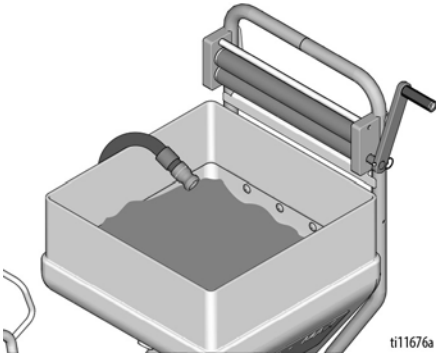

- b. Turn ON/OFF Switch to ON.

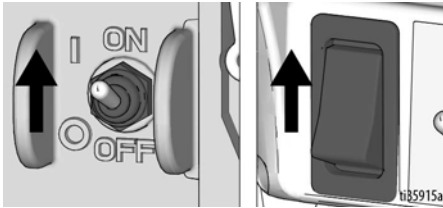

- c. Place Pump Mode Switch in down position. Turn Pressure Control Knob clockwise 1/4 turn.

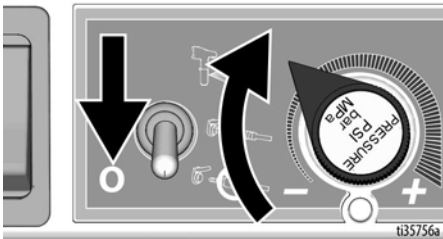

- d. Once a steady stream flows from the material hose, run for an additional 30 seconds.

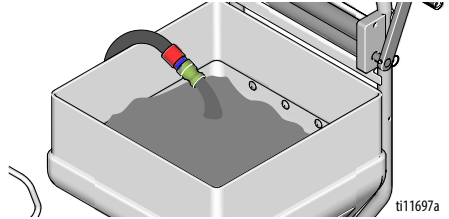

- e. Turn ON/OFF Switch to OFF.

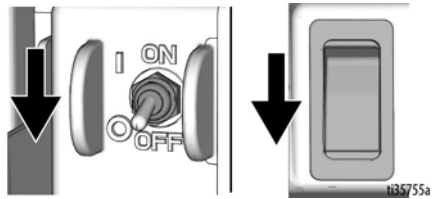

Start Up - Air Assist STX Gun

Start Up - Air Assist STX Gun

1. Turn air needle valve to low setting. Connect applicator to material hose. Connect signal wire connector to gun handle, then the air hose.

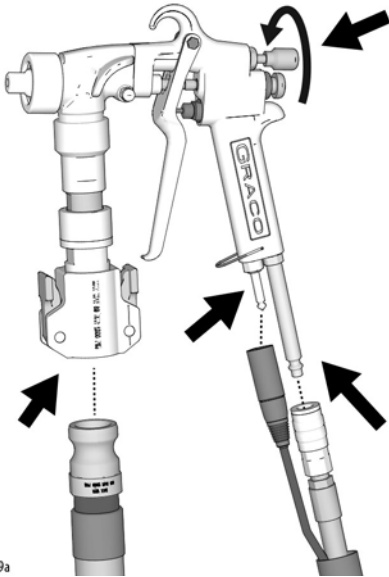

2. Place Pump Mode Switch in center position for remote pump control.

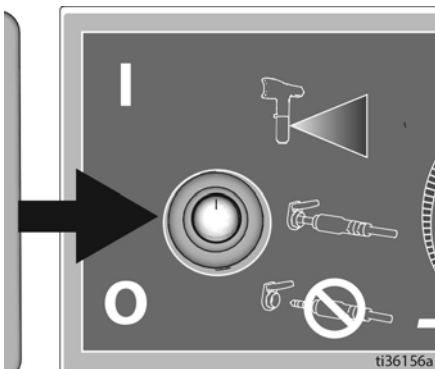

3. Hold applicator over material hopper and turn applicator ON.

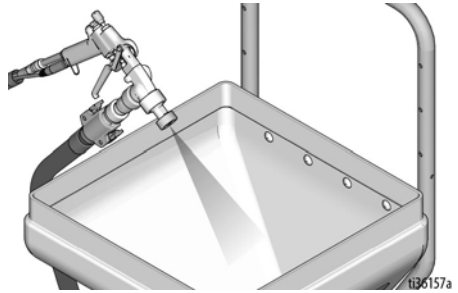

4. Turn Pressure Control Knob clockwise until desired material delivery rate is achieved. Run 15 seconds.



Start Up - Air Assist STX Gun

5. When done spraying, release trigger. The fluid passage will stay open, relieving pressure.
6. When pressure is relieved, press trigger stop button to close fluid passage.

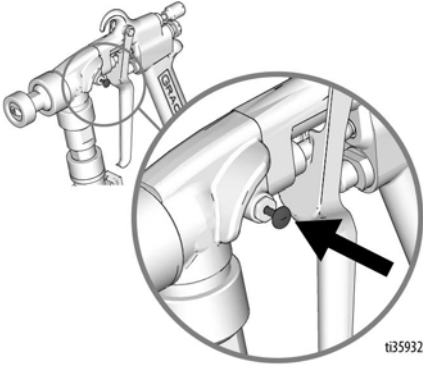

7. Spray test pattern. Aim applicator at floor. Turn air valve ON. Turn applicator ON and move application to spray surface.

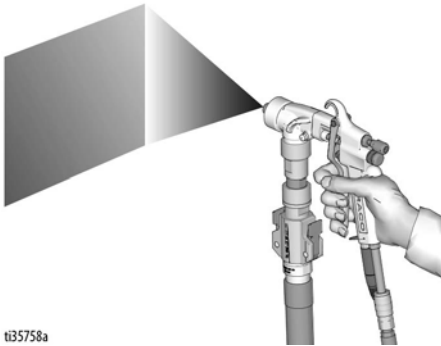

8. Adjust air needle valve and/or select alternative nozzle size (4 - 12mm) for desired finish.

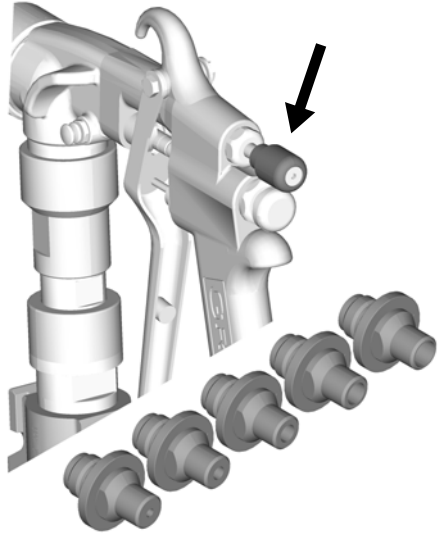



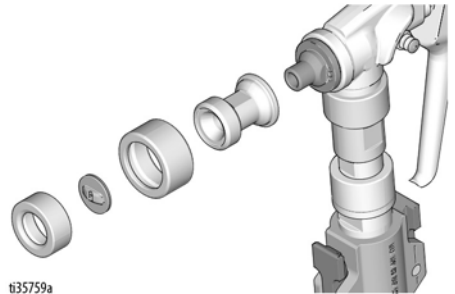

9. If a fan pattern is desired, remove retaining ring and add adapter housing, disk, and retaining nut to the assembly.



10. Select alternative disk (W4 - WXL) for desired finish.





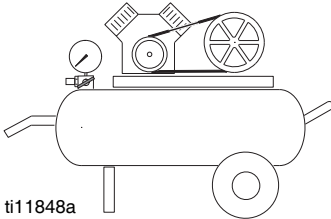

Operation

				
<p>The system has thermal overload protection that will automatically shut down the system if it overheats. To reduce the risk of bodily injury due to the system restarting unexpectedly, always turn the ON/OFF switch to OFF.</p>				

An external air compressor may be connected to the applicator air line fitting. This may be useful for the application of decorative or hard-to-spray materials.



				
<p>Overpressurizing the system may cause component rupture and result in serious injury. To reduce risk of overpressurizing system:</p> <ul style="list-style-type: none">Do not use a compressor with an output pressure greater than 125 psi (0.86 MPa, 8.6 bar).				

The system comes with the following hoses:

T-Max 506:

- Fluid Hose: 5 m of 25 mm ID & 3 m of 19 mm ID

T-Max 657:

- Fluid Hose: 10 m of 25 mm ID & 3 m of 19 mm ID

T-Max 6912:

- Fluid Hose: 5m, 10m, 15m, 30m of 25mm ID & 3m of 19mm ID
- Air Hose: If applicable, 18m or 33m

Hose Usage

Always attach 25 mm ID hose to pump outlet. Other hoses may then be added up to the maximum fluid hose lengths:

- Use shortest fluid hose length required for the spray application (25 mm x 5 m) minimum.
- Unnecessary hose length decreases sprayer performance.
- Maximum fluid hose lengths:

T-Max 506:

- 15 m of 25 mm ID or 10 m of 25 mm ID + 3 m of 19 mm ID

T-Max 657:

- 30 m of 25 mm ID or 25 m of 25 mm ID + 3 m of 19 mm ID

NOTE:

T-Max 6912:

- 30 m of 25 mm ID + 3m of 19mm ID

NOTE: Use only one 3 m of 19 mm ID. Do not exceed 1000 psi. Temperature usage range 0°F - 180°F. All hoses sent with the unit are for water-based material application only.

Cleanup

Storage less than 24 hours

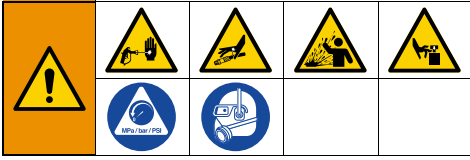

1. Perform **Pressure Relief Procedure**, page 19.
2. Remove applicator. Keep applicator "wet" by placing in water or wrapping with a wet cloth.

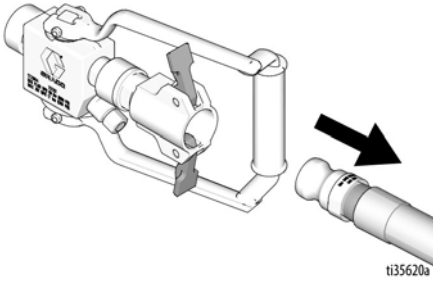

3. Remove hose and couple ends together.

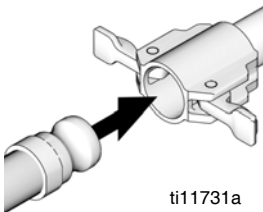
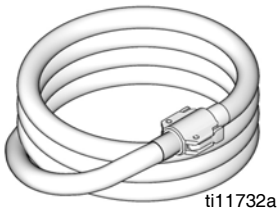

4. Clean hopper sides to material level. Cover material in hopper with hopper cover.

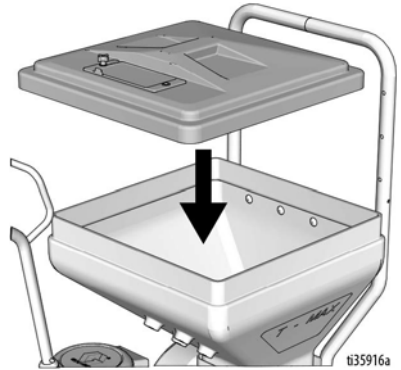

5. Disconnect pump from hopper.

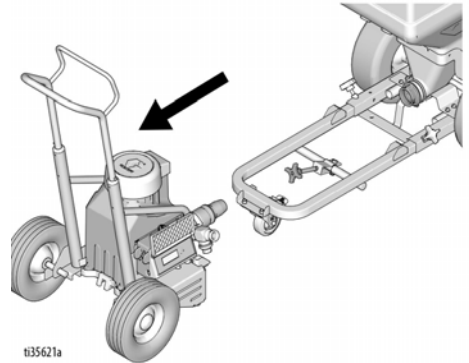
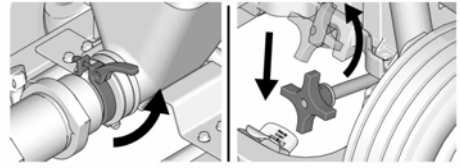

Cleanup

6. Install hopper plug.

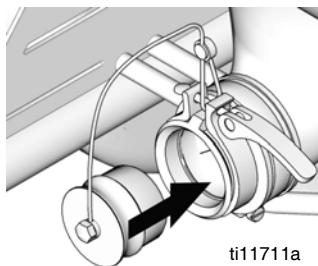

7. Install cap on pump inlet.

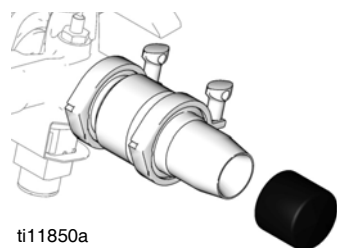

8. Install pump cap (sold separately) on pump outlet.

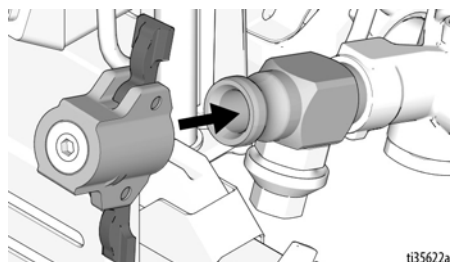

Storage more than 24 hours

1. Perform **Pressure Relief Procedure**, page 19.
2. Shut air OFF if spraying with air. Remove applicator from material hose. Clean applicator.

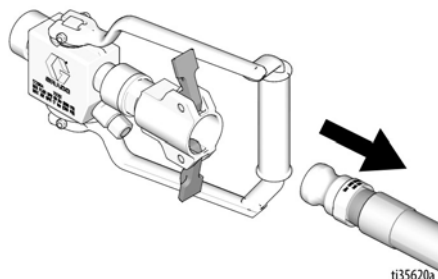

3. Turn Pressure Control Knob clockwise and pump unused texture from material hopper and hose.

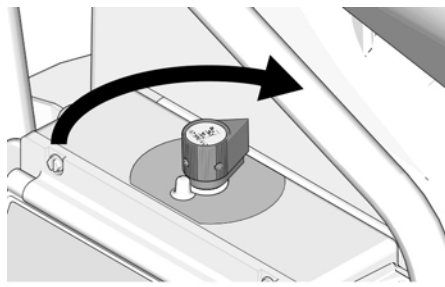

4. Scrape remaining texture in hopper into pump to be pumped from sprayer.

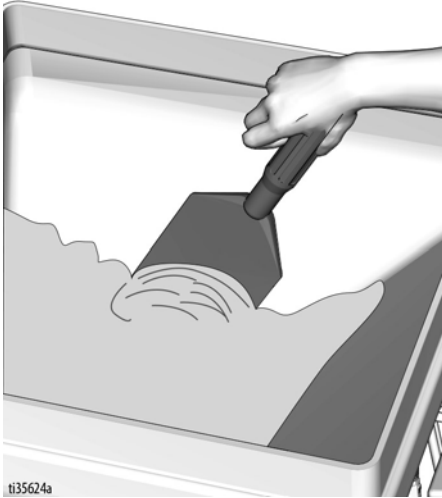

5. Rotate pump control to shut pump OFF.



6. Disconnect material hose from pump outlet.

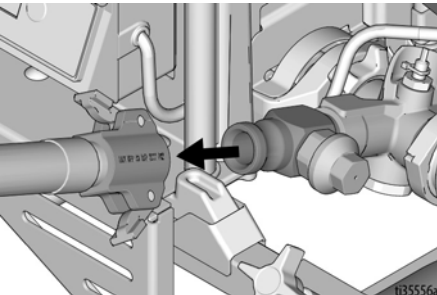

7. Insert two wet cleaning balls into pump outlet. Connect material hose to pump outlet.

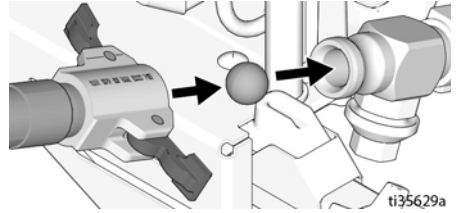

8. Fill material hopper with water and clean sides.

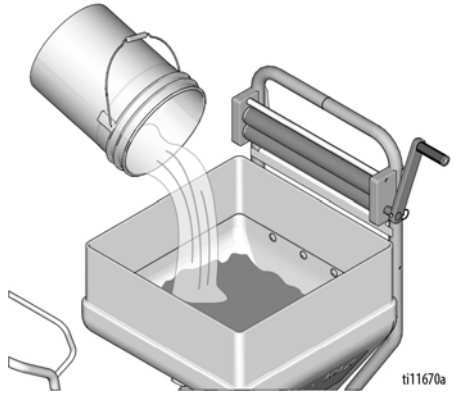

9. Rotate Pressure Control Knob clockwise to start pump.



Cleanup

10. Run pump until cleaning balls exit material hose. Hold material hose securely while passing balls through it. Pressure can build up and make hose jump. Save cleaning balls.

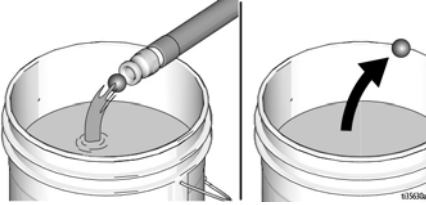

11. Rotate Pressure Control Knob to shut pump OFF.



12. Connect applicator to material hose.

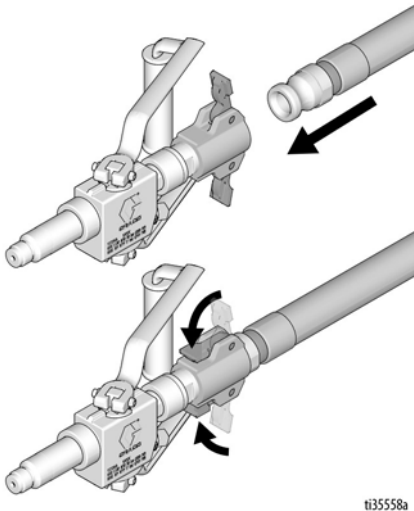

13. Turn Pressure Control Knob clockwise to start pump.



14. Run pump until clean water flows from applicator. Continue until hopper is empty.

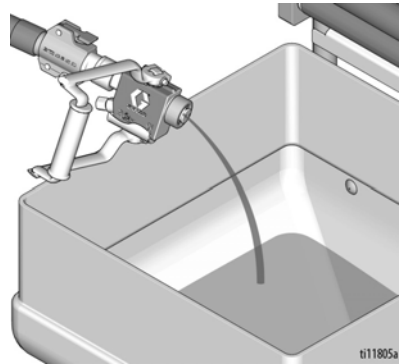

15. Add additional water and repeat steps 13 - 14, if necessary.

NOTE: After flushing with water, flush again with Pump Armor to leave a protective coating to prevent freezing and corrosion.

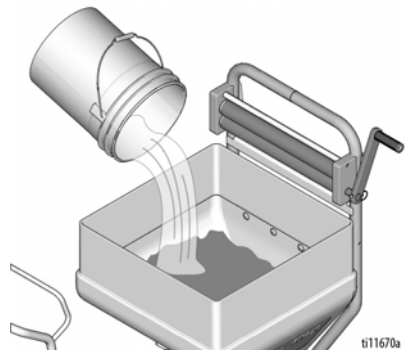

16. Rotate Pressure Control Knob to shut pump off.



17. Disconnect pump from hopper.

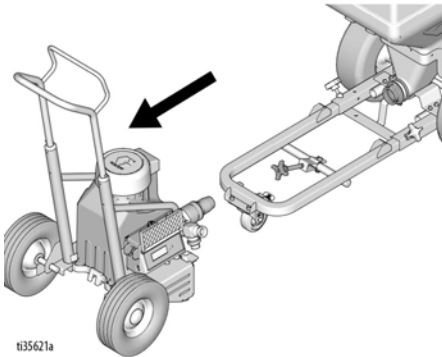
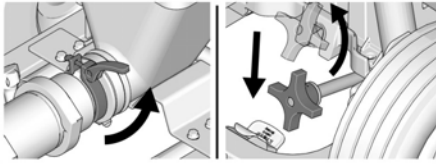

18. Flush hopper with water. Clean and install drain plug.

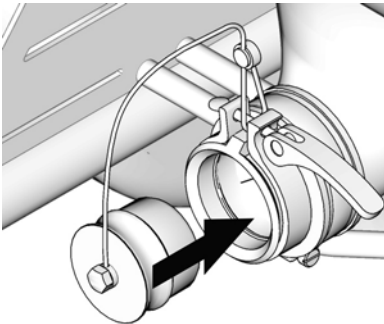

19. Clean applicators, spray tips and guard with brush.

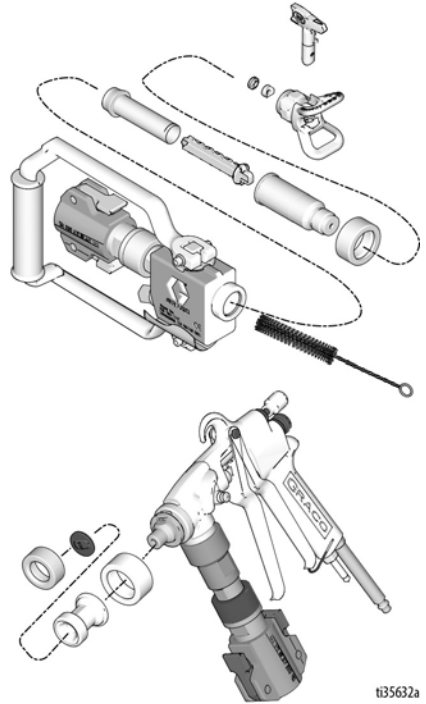

Cleanup

20. Clean hardened material from applicator nozzles with air nozzle cleaner.

NOTICE

Do not use air nozzle cleaner to clean applicator check valve and spray tip. Doing so will damage both items.

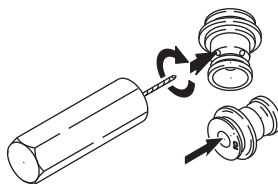

ti11811a

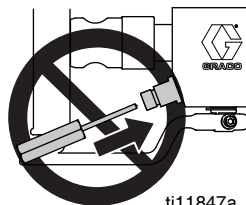

ti11847a

Troubleshooting



1. Follow **Pressure Relief Procedure**, page 19, before checking or repairing.
2. Check all possible problems and causes before disassembling unit.

Motor Will Not Operate

Problem	Cause	Solution
Basic Fluid Pressure Problems	Pressure control knob setting. Motor will not run if at minimum setting (fully counterclockwise).	Slowly increase pressure setting to see if motor starts.
	Spray tip or fluid filter may be clogged.	Relieve pressure and clear clog or clean filter; refer to separate gun or tip instruction manual.
	Pump mode switch is not in the proper position (6912).	Place the pump mode switch in proper position for application. Up: Pressure Mode Middle: Remote Control Down: Flow Mode
	Builds pressure but material will not come out.	Perform Pressure Relief Procedure , page 19. Check applicator, hose, and pump for packout. May need to remove outlet spring if packout in pump is reoccurring.
Basic Mechanical Problems	Frozen or hardened paint.	Thaw sprayer if water or water-based paint has frozen in sprayer. Place sprayer in warm area to thaw. Do not start sprayer until thawed completely. If paint hardened (dried) in sprayer, replace pump packing. See Pump Repair , page 58.
	Displacement pump connecting rod pin. Pin must be completely pushed into connecting rod and retaining spring must be firmly in groove of pump pin.	Push pin into place and secure with spring retainer.
	Motor. With machine unplugged, remove drive housing assembly. Try to rotate fan by hand.	Replace motor if fan won't turn.

Troubleshooting

Problem	Cause	Solution
Basic Electrical Problems	Motor control board. Board shuts down and displays error code.	See Control Board Diagnostics , page 43.
	Electrical supply. Meter must read: 210-255 Vac for 220-240 Vac models; 85-130 Vac for 100-120 Vac models.	Reset building circuit breaker; replace building fuse. Try another outlet.
	Extension cord. Check extension cord continuity with volt meter.	Replace extension cord.
	Sprayer power supply cord. Inspect for damage such as broken insulation or wires.	Replace power supply cord.
	Check that motor leads are securely fastened and properly mated.	Replace loose terminals; crimp to leads. Be sure terminals are firmly connected. Clean circuit board terminals. Securely reconnect leads.
	ON/OFF Switch. Connect volt meter between L1 and L2 terminal on ON/OFF switch. Plug in sprayer and turn ON. Meter must read: 210-255 Vac for 220-240V models 85-130 Vac for 100-120V models.	Replace ON/OFF switch.
	Check all terminals for damage or loose fit.	Replace damaged terminals and reconnect securely.

Motor is Hot and Runs Intermittently

Problem	Cause	Solution
Motor is hot and runs intermittently.	Determine if sprayer was operated at high pressure with small tips, which causes low motor RPM and excessive heat build up	Decrease pressure setting or increase tip size.
	Be sure ambient temperature where sprayer is located is no more than 90°F and sprayer is not located in direct sun	Move sprayer to shaded, cooler area if possible.

Low or Fluctuating Output

Problem	Cause	Solution
Low Output	Worn spray tip.	Follow Pressure Relief Procedure Warning, then replace tip. See your separate gun or tip manual.
	Verify pump does not continue to stroke when applicator is turned off.	Service pump. Check piston and intake valves for wear or obstructions.
	Filter clogged (If optional filter is installed).	Relieve pressure. Check and clean filter.
	Material hose length. Longer hose length reduces sprayer performance.	Replace with hose length less than specified maximum.
	Pump hopper adapter connections.	Tighten any loose connections. Replace pump hopper adapter if cracked or punctured.
	Electrical supply with volt meter. Meter must read: 210-255 Vac for 220-240 Vac models; 85-130 Vac for 100-120 Vac models. Low voltages reduce sprayer performance.	Reset building circuit breaker; replace building fuse. Repair electrical outlet or try another outlet.
	Extension cord size and length; must be at least 2.05 mm ² (12 awg) wire and no longer than 90 m (295 ft). Longer cord lengths reduce sprayer performance.	Replace with a correct, grounded extension cord.
	Leads from motor to pressure control circuit board for damaged or loose wires or connectors. Inspect wiring insulation and terminals for signs of overheating.	Be sure male terminal blades are centered and firmly connected to female terminals. Replace any loose terminal or damaged wiring. Securely reconnect terminals.
	Low stall pressure.	Turn pressure control knob fully clockwise. Make sure pressure control knob is properly installed to allow full clockwise position. Try a new transducer. Check pump control mode. If used in middle position, the pump is limited to 600 psi.
Fluctuating Output	Material supply.	Refill hopper and reprime pump.
	Loose fittings.	Tighten; use thread sealant or sealing tape on threads if necessary.
	Intake valve ball and piston ball are not seating properly.	Remove intake and piston valves and clean. Check balls and seats for nicks or obstructions; replace if necessary, page 58. Clean hopper before using to remove particles that could clog pump. Switch to a rubber inlet ball (6912).
	Leaking around throat packing nut which may indicate worn or damaged packings.	Replace packing, page 58. Also check piston valve seat for hardened paint or nicks and replace if necessary.
	Pump rod damage.	Repair pump.

Troubleshooting

Problem	Cause	Solution
Motor runs but pump does not stroke	Pump pin damaged or missing.	Replace pump pin if missing. Be sure retainer spring is fully in groove all around connecting rod.
	Connecting rod assembly is damage.	Replace connecting rod assembly.
	Gears or drive housing.	Inspect drive housing assembly and gears for damage and replace if necessary.

Electrical Short

NOTICE

A short in any part of the motor power circuit will cause the control circuit to inhibit sprayer operation. Correctly diagnose and repair all shorts before checking and replacing control board.

Problem	Cause	Solution
Building circuit breaker opens as soon as sprayer switch is turned on.	All electrical wiring for damaged insulation, and all terminals for loose fit or damage. Also wires between pressure control and motor.	Repair or replace any damaged wiring or terminals. Securely reconnect all wires.
	Motor armature for shorts. Inspect windings for burns	Replace motor.
	Motor control board by performing motor control board diagnostics. If diagnostics indicate, substitute with a good board.	Replace with a new motor control board.
Building circuit breaker opens as soon as sprayer is plugged into outlet and sprayer is NOT turned on.	Basic Electrical Problems on page 41.	Perform necessary procedures.
	For damaged or pinched wires in pressure control.	Replace damaged parts.
Sprayer quits after sprayer operates for 5 to 10 minutes.	Basic Electrical Problems.	Perform necessary procedures.
	Electrical supply with volt meter. Meter must read: 210-255 Vac for 220-240 Vac models; 85-130 Vac for 100-120 Vac models.	If voltage is too high, do not operate sprayer until corrected.

Repair

Control Board Diagnostics



1. Perform **Pressure Relief Procedure**, page 19.

NOTE: Do not allow sprayer to develop fluid pressure without transducer installed. Leave pump outlet open if test transducer is used.

2. Observe display messages in the following table.

3. Observe LED operation and reference the following table.

Display	Control board status LED Blinks	Spray Operation	Indicates	What to Do
No Display	Never blinks	Spray stops. Power is not applied. Sprayer must be pressurized.	Loss of power.	Check power source. Perform Pressure Relief Procedure , page 19, before repair or disassembly.
psi/bar/MPa	Once	Sprayer is pressurized. Power is applied. (Pressure varies with tip size and pressure control setting.)	Normal operation.	Do nothing.
E=02 CODE 02	Two times repeatedly	Sprayer may continue to run. Power is applied.	Run away pressure. Pressure greater than 1500 psi (103 bar, 10.3 MPa) or damaged pressure transducer.	Replace motor control board or pressure transducer.
E=03 CODE 03	Three times repeatedly	Sprayer shuts down and LED continues to blink three times repeatedly	Pressure transducer is faulty or missing.	Check transducer connection. Open drain valve. Substitute new transducer for transducer in sprayer. If sprayer runs, replace transducer.
E=04 CODE 04	Four times repeatedly	Sprayer does not operate.	Control board is detecting multiple voltage surges.	Check voltage switch, ensure it is in the right voltage setting for the voltage being used. Set Sprayer to OFF and disconnect power to sprayer. Locate a good voltage supply to prevent damage to electronics.
E=05 CODE 05	Five times repeatedly	Sprayer does not start or stops and LED continues to blink five times repeatedly. Power is applied.	Motor fault.	Check for locked rotor, shorted wiring or disconnected motor. Repair or replace failed parts.
E=06 CODE 06	Six times repeatedly	Sprayer stops and LED blinks six times repeatedly. Power is applied.	Motor is too hot or there is a fault in motor thermal device.	Allow sprayer to cool. If sprayer runs correctly when cool, check motor fan function and air flow. Keep sprayer in cool location. If sprayer does not run when cool and continues to blink six times, replace motor.

Display	Control board status LED Blinks	Spray Operation	Indicates	What to Do
CODE 08	Eight times repeatedly	Sprayer does not operate.	Voltage supply to low.	Set sprayer to OFF and disconnect power to sprayer remove other equipment that uses the same circuit. Locate a good voltage supply to avoid damage to electronics.
CODE 10	Ten times repeatedly	Sprayer does not operate.	Overheating control board	Make sure motor air intake is not blocked. Make sure fan has not failed. Make sure control board is properly connected to back plate and that conductive thermal paste is used on power components. Replace control board. Replace motor.
CODE 12	Twelve times repeatedly	Sprayer does not operate.	Excessive current protection enabled.	Cycle power on and off.
CODE 15	Fifteen times repeatedly	Sprayer does not operate.	Motor connection problem.	Set sprayer to OFF and disconnect power to sprayer. Remove motor shroud. Disconnect motor control and inspect for damage at connectors.
CODE 16	Sixteen times repeatedly	Sprayer does not operate.	Control is not receiving a motor position signal.	Turn power OFF. Disconnect motor position sensor and inspect for damage at connectors. Reconnect sensor. Turn power on. If problem continues, replace motor.
CODE 17	Seventeen times repeatedly	Sprayer does not operate.	Wrong voltage detected.	Check voltage switch, ensure it is in the right voltage setting for the voltage being used. Set Sprayer to OFF and disconnect power to sprayer. Locate a good voltage supply to prevent damage to electronics.
---		Power is applied.	Pressure less than 60 psi (4.1 bar, 41 MPa).	Increase pressure if desired. Drain valve may be open.

Control Board Removal 506/657



1. Perform **Pressure Relief Procedure**, page 19. Unplug power cord to disconnect power.
2. Separate pump from hopper.

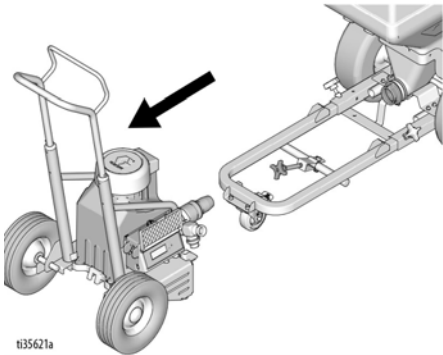
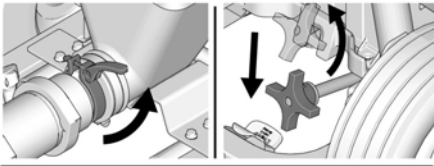

ti35621a

3. Remove four screws and motor cover.

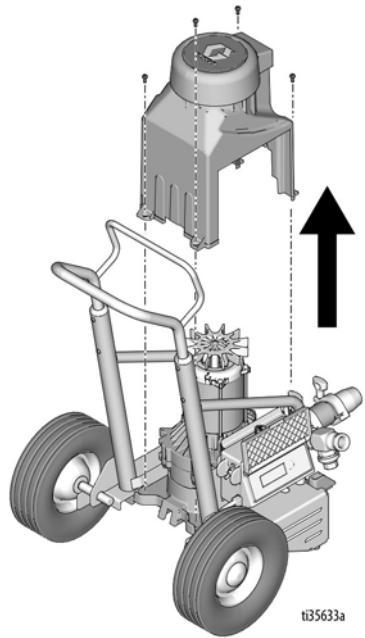

ti35633a

4. Remove four screws and control cover. Disconnect display from control board.

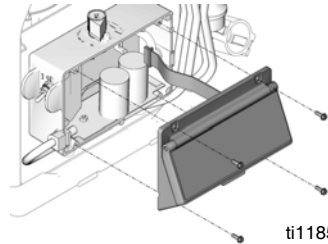

ti11854a

Repair

5. Reference Wiring Diagram, page 81. Remove screw. Disconnect ground, blue and brown leads.

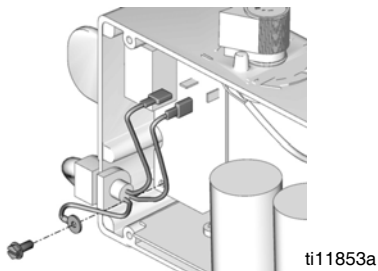

6. Remove power cord from control box.

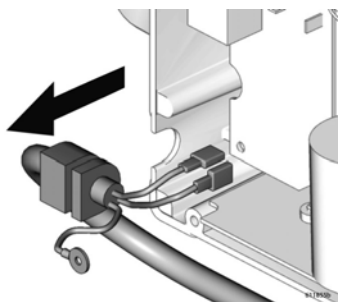

7. Remove filter board screws.

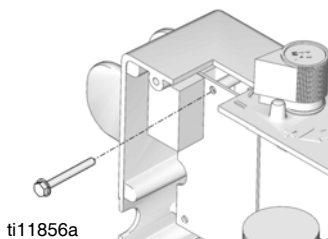

8. Remove ON/OFF switch toggle boot.

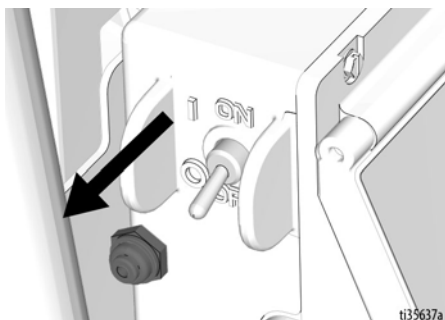

9. Disconnect black lead from control board to filter board.

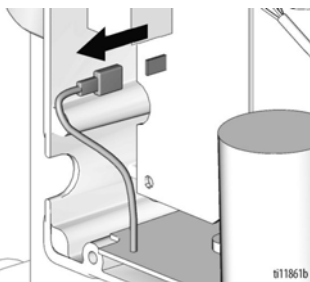

10. Remove filter board from control box.

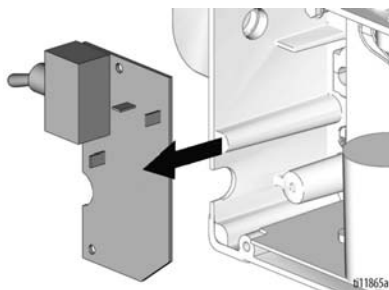

11. Remove screw from bottom of control box.

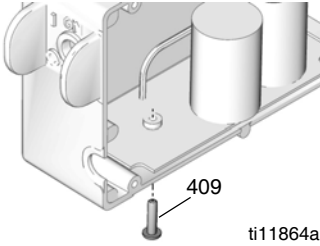

12. Disconnect motor (A), thermister (B), potentiometer (C) and transducer (D) connectors. Remove grommet (E).

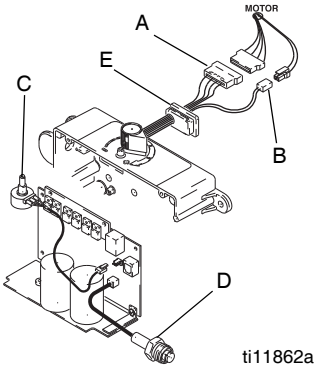

13. Remove four screws and control board.

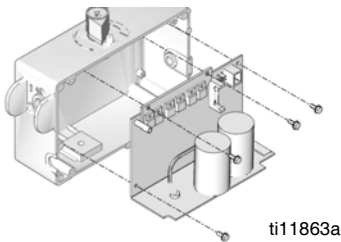

Control Board Installation 506, 657

1. Install control board with four screws.

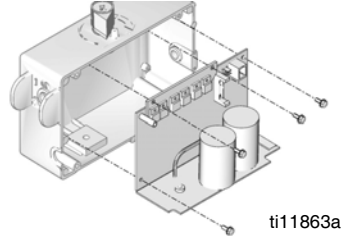

2. Connect motor (A), thermister (B), potentiometer (C) and transducer (D) connectors. Install grommet (E).

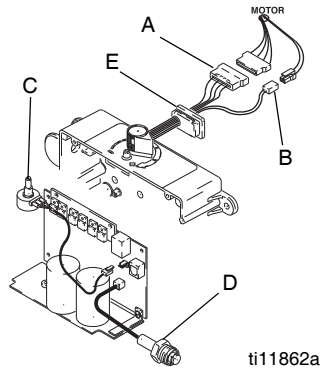

3. Install screw through bottom of control box.

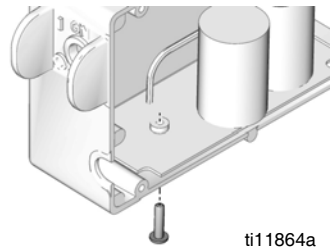

Repair

4. Install filter board in control box.

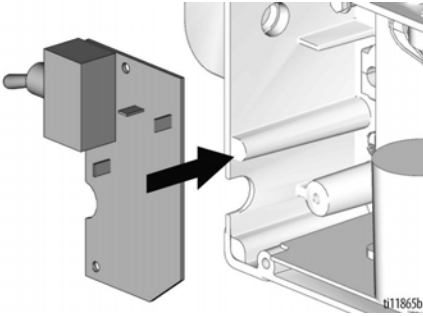

5. Connect black lead from control board to filter board.

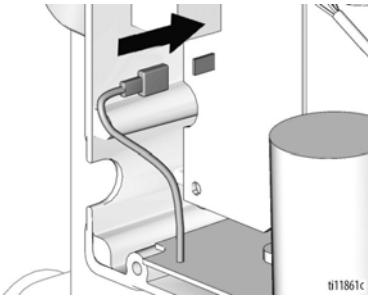

6. Install ON/OFF switch toggle boot.

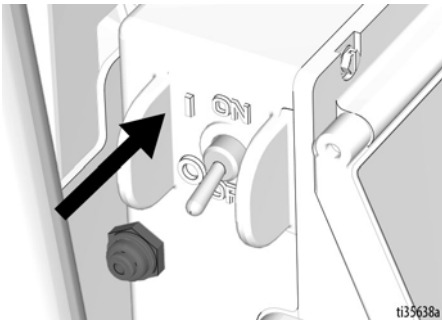

7. Install filter board screw.

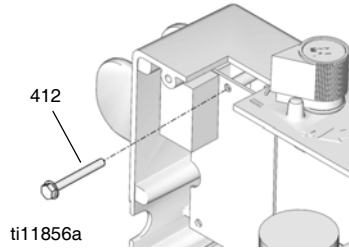

8. Install power cord (C) in control box.

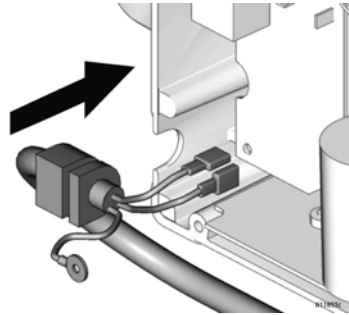

9. Reference **Wiring Diagram**, page 81. Connect ground, blue and brown leads. Install screw.

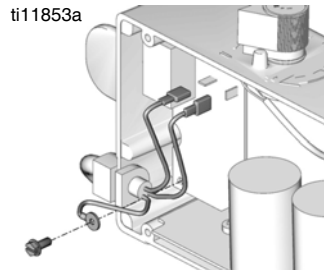

10. Connect display to control board. Install control cover with four screws.

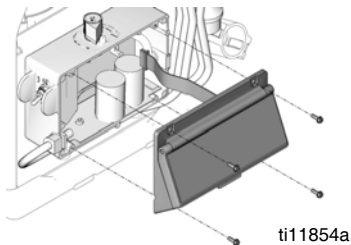

11. Install motor cover with four screws.

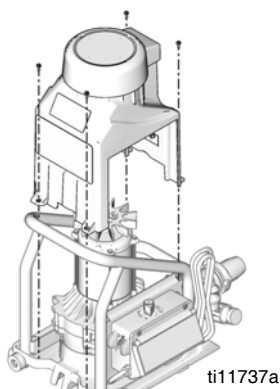

Control Board Removal 6912



1. Perform **Pressure Relief Procedure**, page 19. Unplug power cord to disconnect power.
2. Separate pump from hopper.

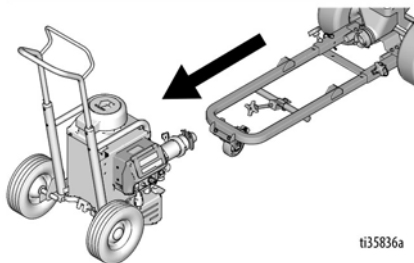
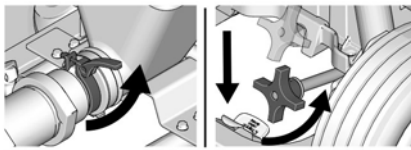

Repair

3. Remove four screws and motor cover.

4. Remove four screws and open cover.

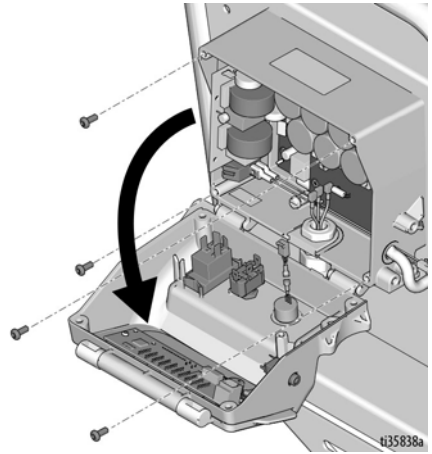
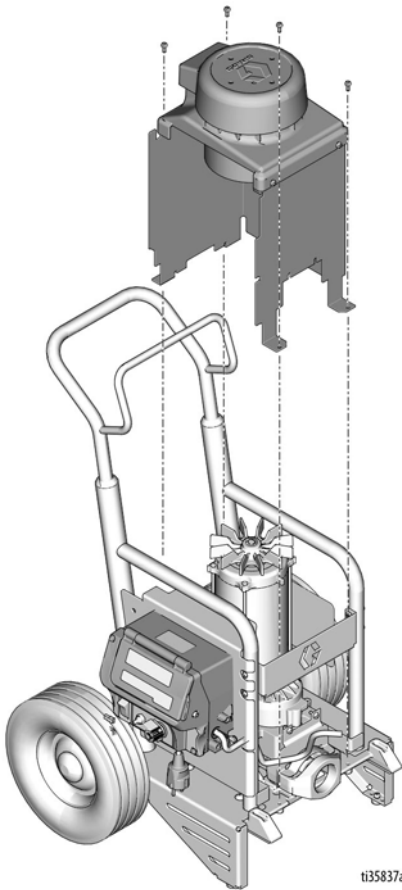

5. Remove two screws and remove filter board and amp switch.

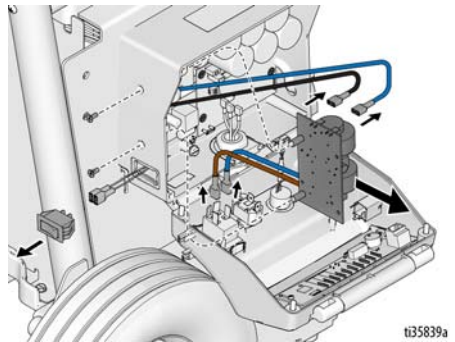

6. Reference **Wiring Diagrams**, page 82. Disconnect mode switch (yellow and black), transducer, potentiometer, amp switch, LED display filter board (black, blue). Remove front cover.

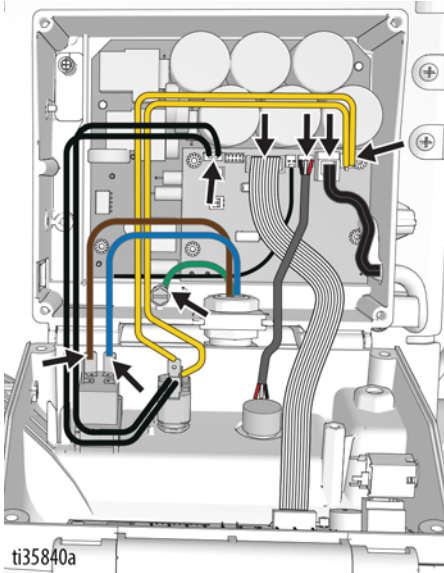

7. Disconnect motor leads, thermal switch, and motor hall/encoder sensor. Remove motor grommet.

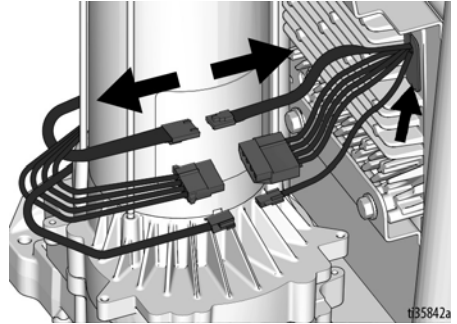

8. Remove two screws from back of control box and remove box.

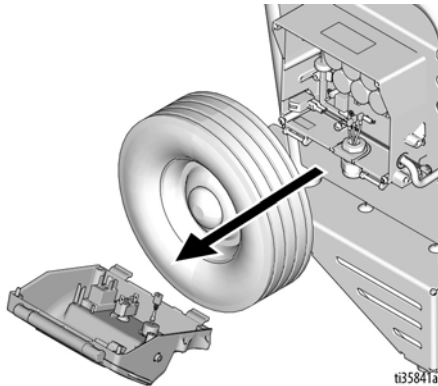
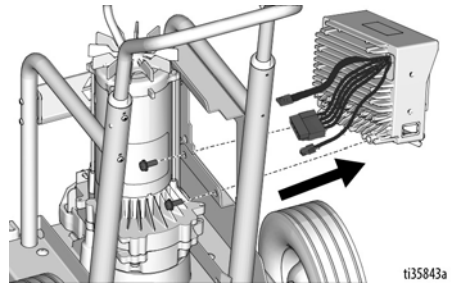

Control Board Installation 6912

1. Install control box with two screws.

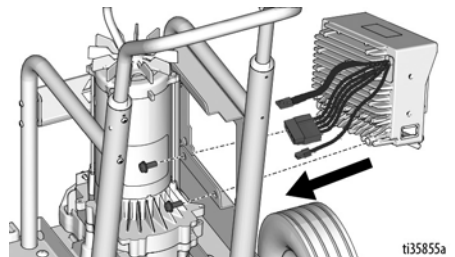

Repair

2. Connect motor leads, thermal switch, and motor hall/encoder sensor. Install grommet.

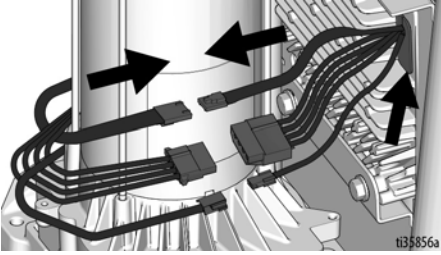

3. Reference **Wiring Diagrams**, page 82. Connect mode switch (yellow and black), transducer, potentiometer, amp switch, LED display filter board (black, blue).

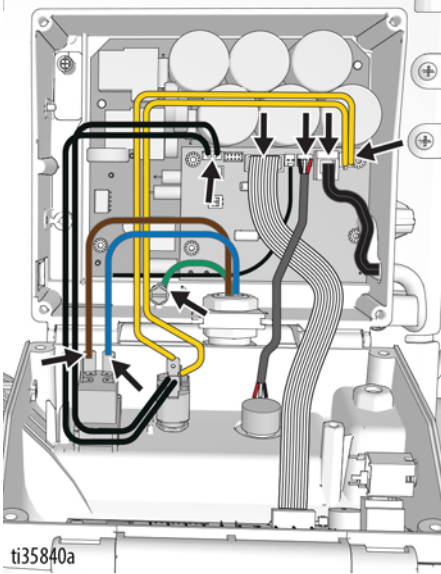

4. Install filter board in control box with two screws. Install amp switch.

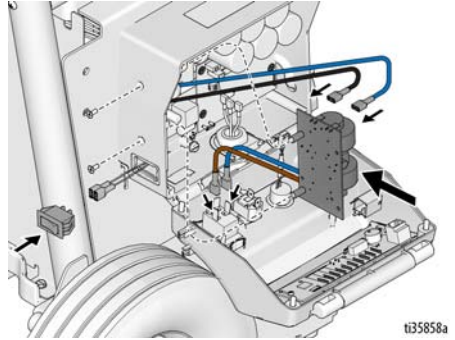

5. Close cover and install four screws.

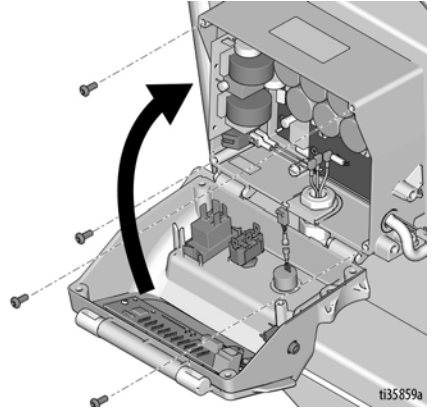

6. Install motor cover using four screws.

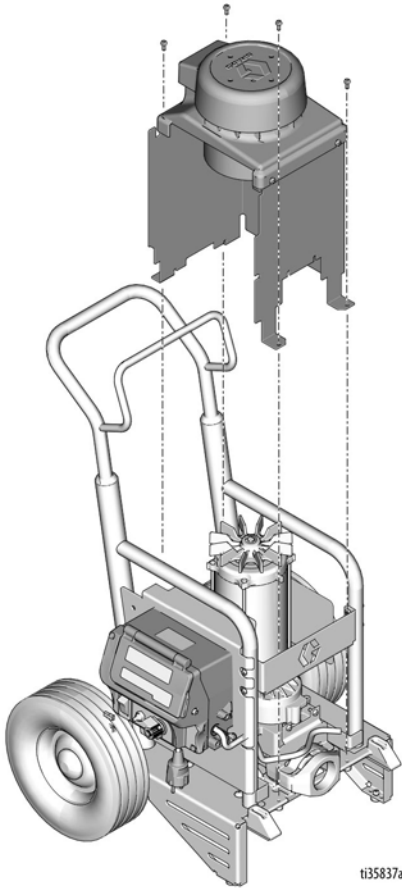

7. Connect pump to hopper.

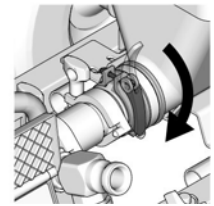
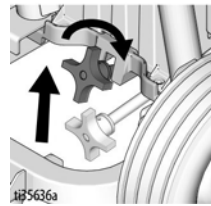
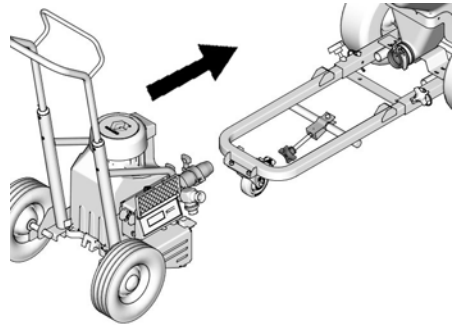

Pump Removal



1. Perform **Pressure Relief Procedure**, page 19. Unplug power cord to disconnect power.
2. Perform **Storage more than 24 hours** procedure, page 34.
3. Separate pump from hopper.

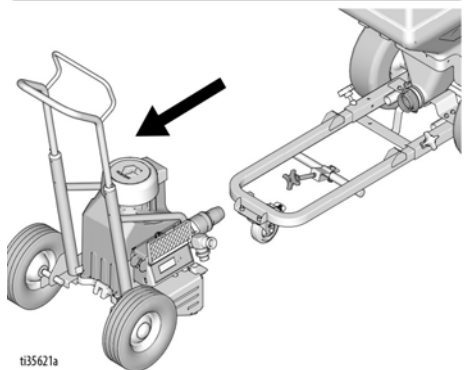
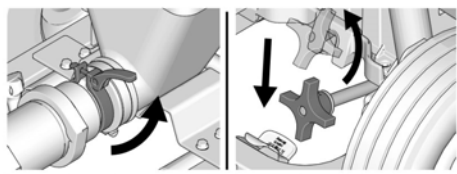

4. Remove four screws and motor cover.

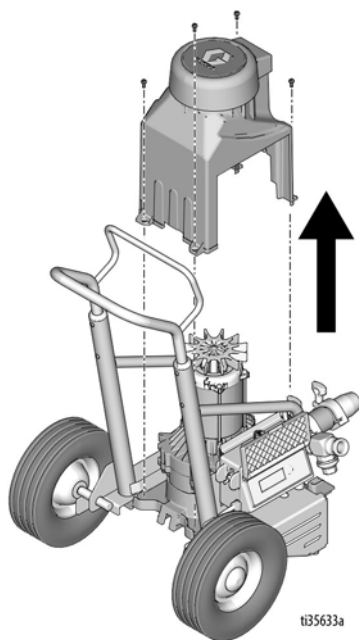

5. Remove four screws and control cover.

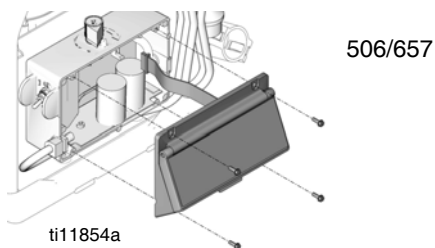

6912

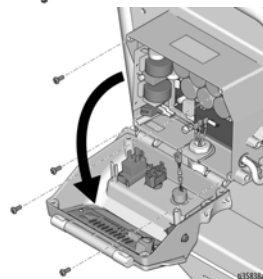

6. Disconnect transducer from control board. Remove transducer and strain relief from control box.

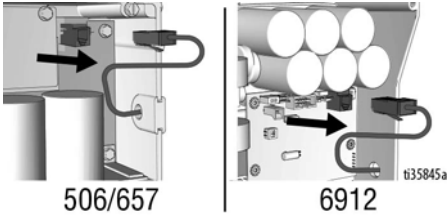

7. Slowly rotate fan blade on motor until connecting rod is at bottom of stroke.

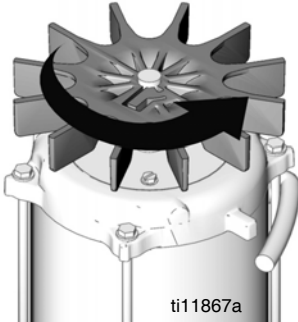

8. Pry retaining spring up on connecting rod toward motor. Push pump pin out with a screwdriver.

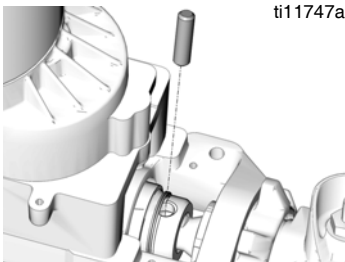

9. Loosen retaining nut.

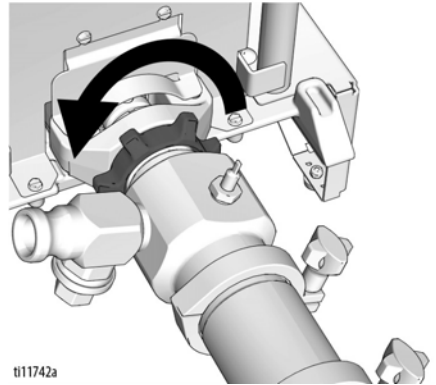

10. Unscrew pump from bearing housing.

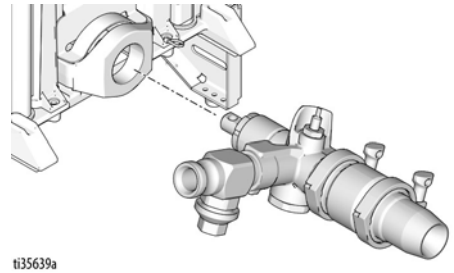

Pump Installation

1. Push piston rod out of pump 50 to 70 mm (2 to 2.8 in.).

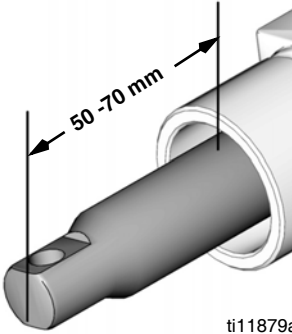

ti11879a

2. Screw retaining nut onto pump until it stops. Screw pump into bearing housing until pump stops. Unscrew pump until pump outlet is 13° from horizontal, but no more than one turn.

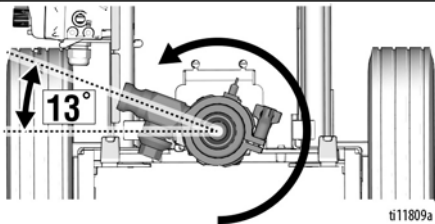
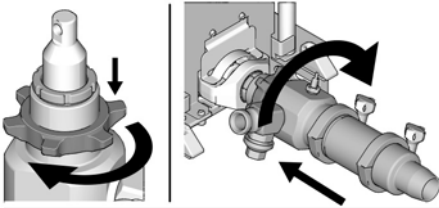



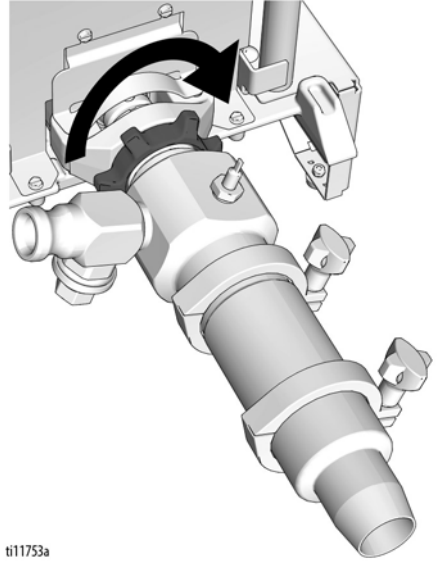

ti11809a

3. Tighten retaining nut.



ti11753a

			
<p>If pump pin loosens, parts may break off due to force of pumping action. Parts may project through the air and result in serious injury or property damage. Make sure pump pin and retaining spring are properly installed.</p>			

4. Push retaining spring up with a screwdriver toward motor. Push in pump pin. Push retaining spring down over pump pin.

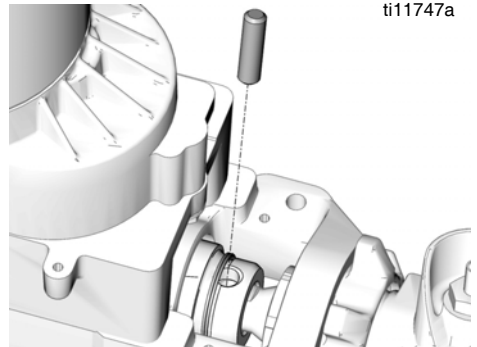

ti11747a

5. Install transducer and strain relief in control box. Connect transducer to control board.

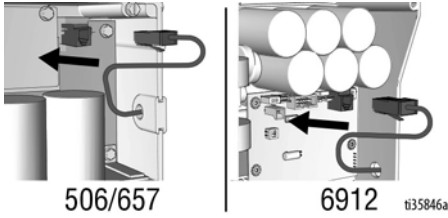

6. Install control cover with four screws.

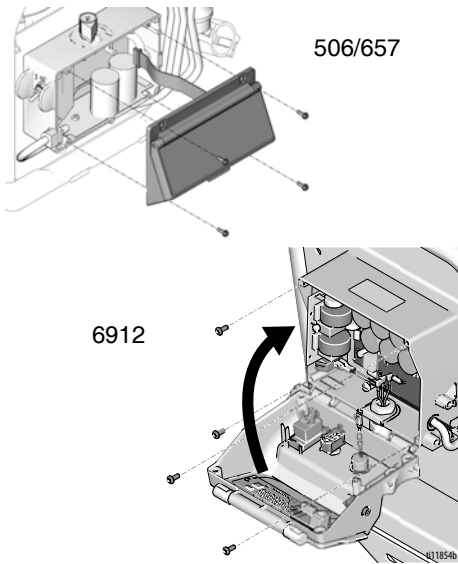

7. Install motor cover with four screws.

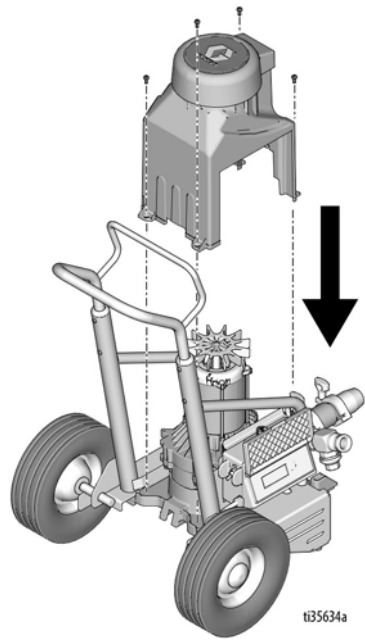

8. Connect pump module.

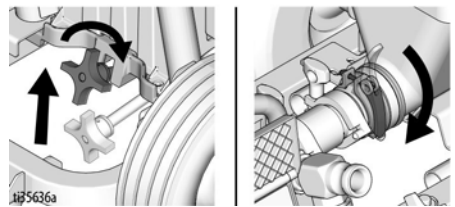
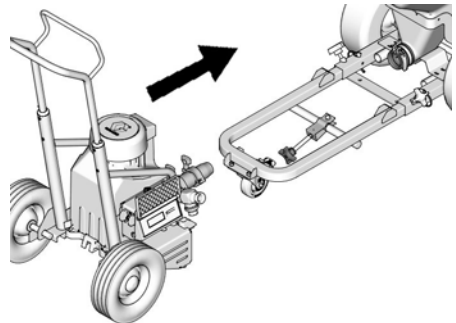

Pump Repair 506/657



Disassembly

NOTE: It may be easier to leave the pump connected to the connecting rod and bearing housing if the only assemblies to be cleaned and inspected are the intake housing or piston valve.

1. Perform **Pressure Relief Procedure**, page 19. Unplug power cord to disconnect power.
2. Refer to **Pump Removal**, page 54, to remove pump.
3. Remove clamp and intake housing.

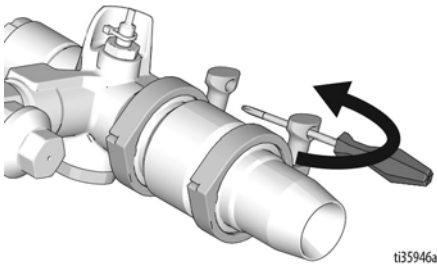

4. Remove clamp and pump cylinder.

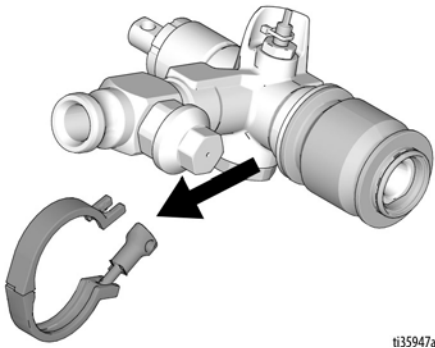

5. Remove packing nut. Push piston rod from outlet housing.

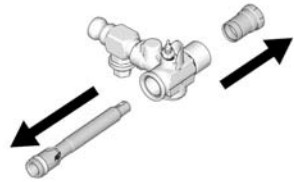
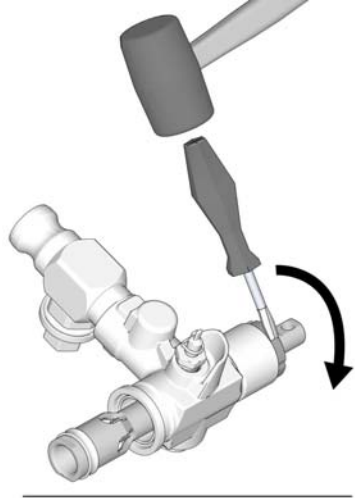

6. Place end of piston rod in vise and remove piston valve (12). Remove piston seal (16). Inspect all parts for nicks and scratches. Replace worn or damaged parts as they may result in poor pump performance.

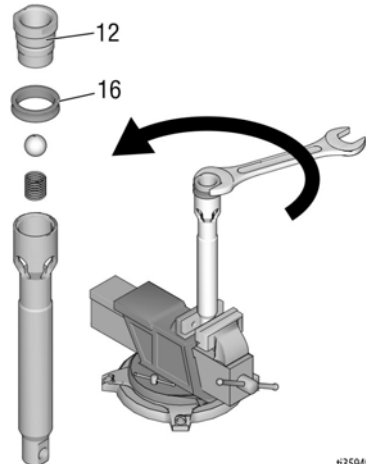

Assembly

1. Place end of piston rod in vise. Install new piston seal. Torque piston valve to 27 ft-lb (36,6 N·m).

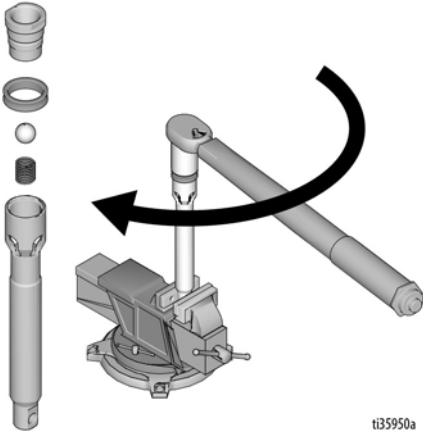

2. Install packing nut. Hand tighten then tap with screw driver. Push piston rod into outlet housing. Extend piston rod 50 - 75 mm (A) out of outlet housing.

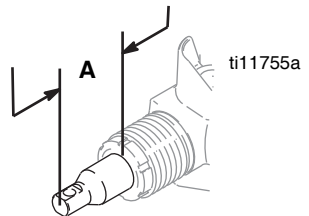
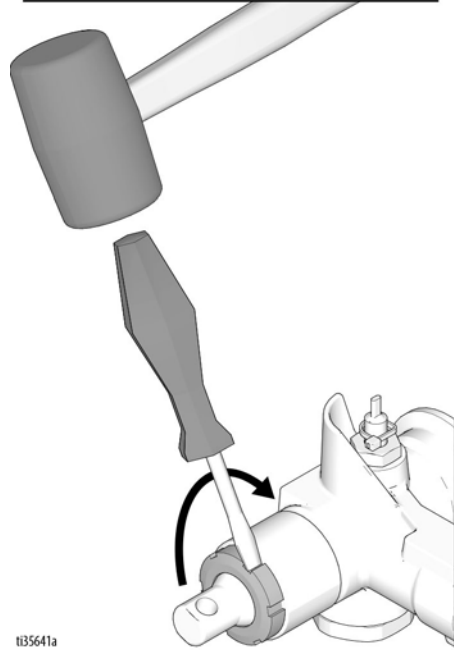
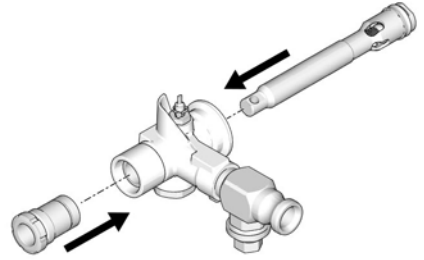

3. Install clamp on pump cylinder. Torque clamp to 100in-lb (11.3 Nm).

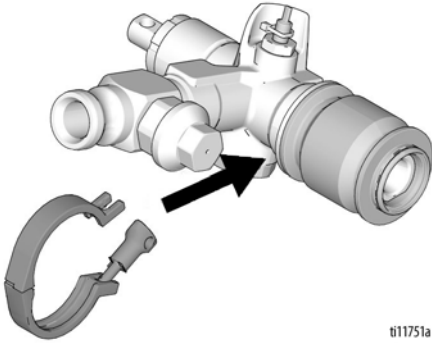

4. Install clamp on intake housing. Torque clamp to 100in-lb (11.3 Nm).

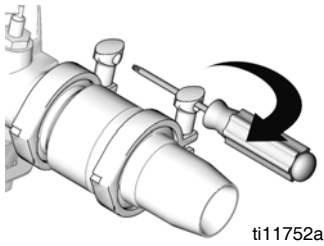

5. Refer to **Pump Installation**, page 56, to install pump.

Pump Repair 6912



Disassembly

NOTE: It may be easier to leave the pump connected to the connecting rod and bearing housing if the only assemblies to be cleaned and inspected are the intake housing or piston valve.

1. Perform **Pressure Relief Procedure**, page 19. Unplug power cord to disconnect power.
2. Refer to **Pump Removal**, page 54, to remove pump.
3. Remove clamp and intake housing.

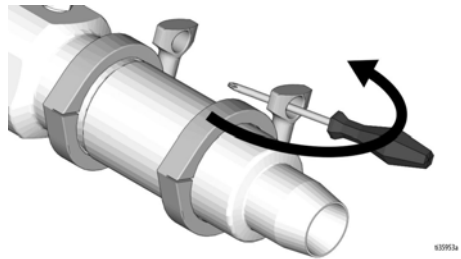

4. Disassemble intake valve.

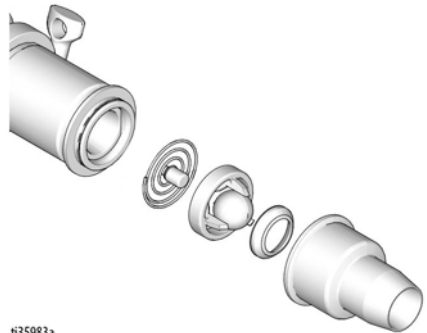

5. Remove clamp and pump cylinder.

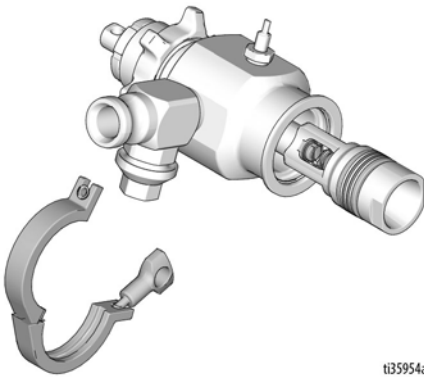

ti35954a

6. Remove packing nut. Push piston rod from outlet housing. Remove throat packings and glands from cylinder. Discard throat packings and glands.

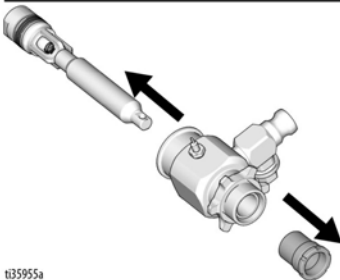
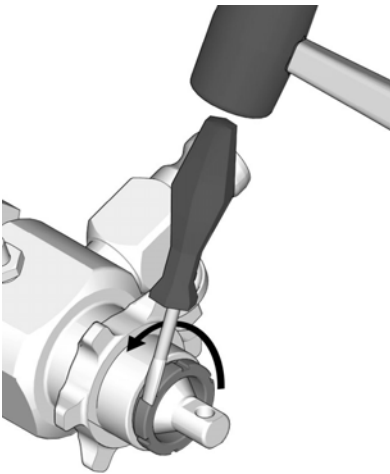

ti35955a

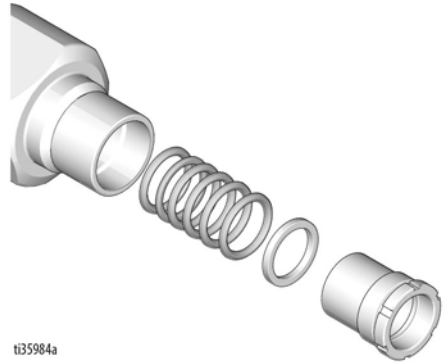

ti35984a

7. Place cage of piston rod in vise and remove piston valve. Remove piston seal. Remove packings and glands from piston rod. Inspect all parts for nicks and scratches. Replace worn or damaged parts as they may result in poor pump performance.

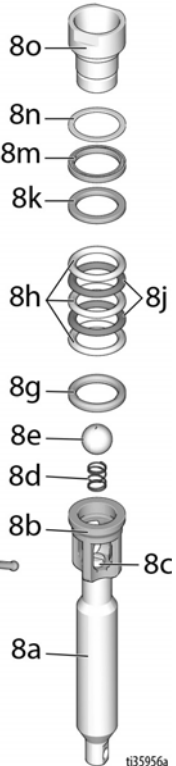
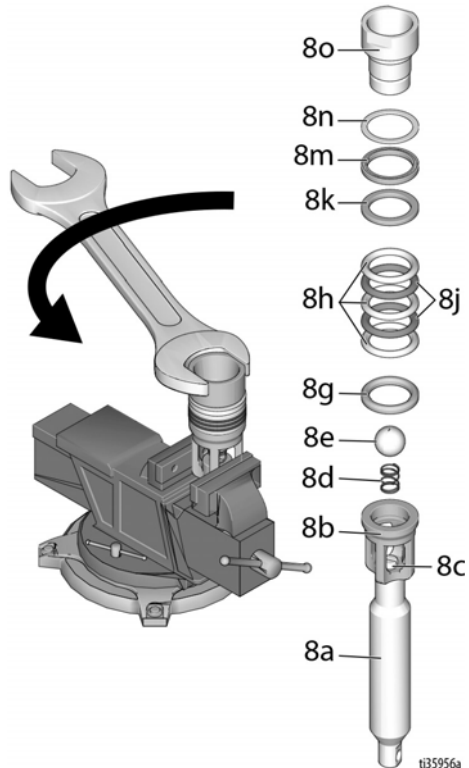

ti35956a

Repair

Assembly

1. Place cage of piston rod in vise. Install new piston seal. Torque piston valve to 90 ft-lb (122 N·m). Install piston wiper (note orientation, page 63) and backup washer on piston valve, threads are good for four repackings. Use thread sealant on piston valve threads after four repackings. Stack male gland on piston rod. Alternately stack light and dark packings (note orientation, page 63) on piston rod. Install female gland.

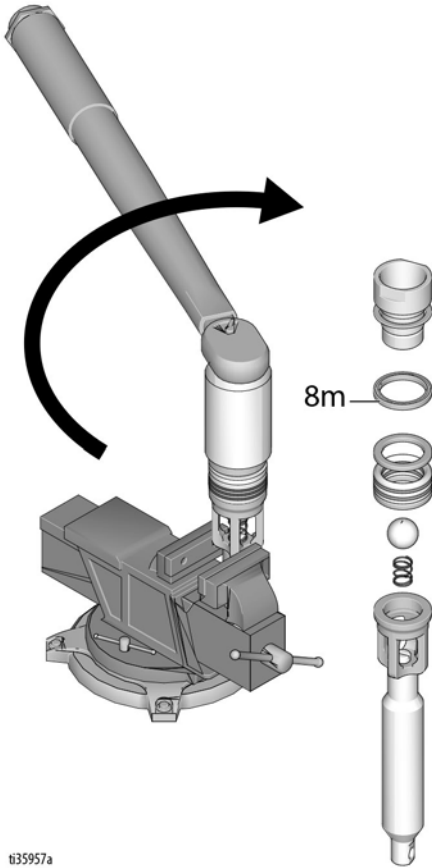

t135957a

2. Install packing nut. Hand tighten then tap with screw driver. Push piston rod into outlet housing. Extend piston rod 50 - 75 mm (A) out of outlet housing.

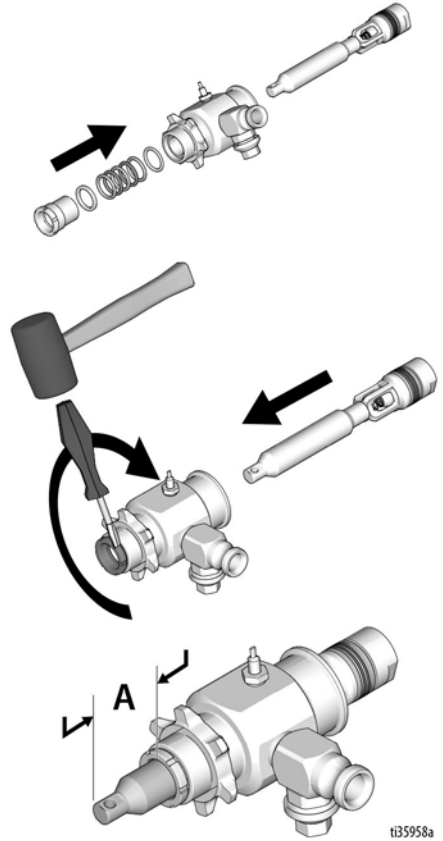

t135958a

Cross-Section Reference / Pump Ball Identification 6912

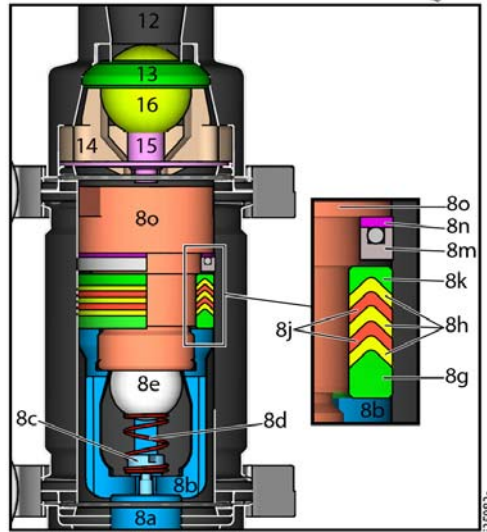
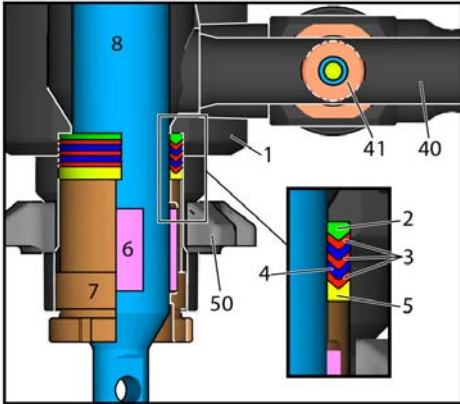
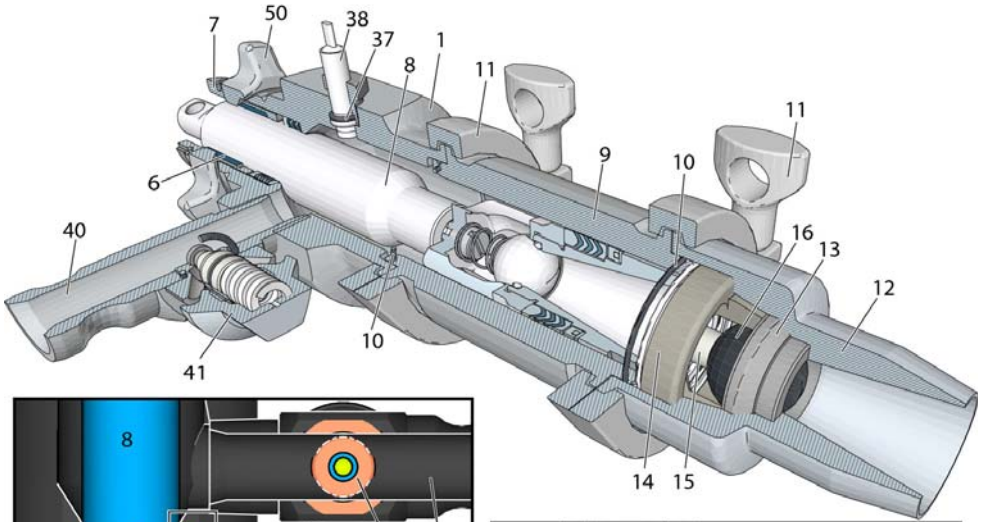

T-MAX 6912 PUMP BALL IDENTIFICATION



Motor Removal



1. Perform **Pressure Relief Procedure**, page 19. Unplug power cord to disconnect power.
2. Remove pump. See **Pump Removal**, page 54.
3. Tip unit on back.

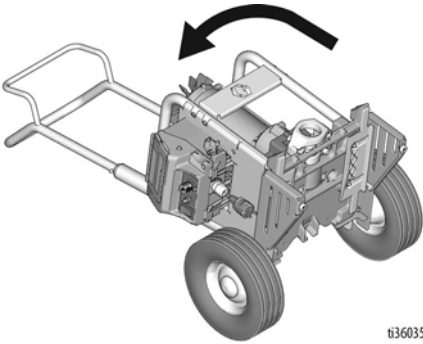

ti36035a

4. While supporting motor/drive housing, remove two screws from base.

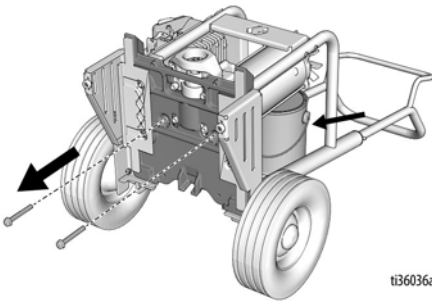

ti36036a

5. Remove four screws, washers and bearing housing.

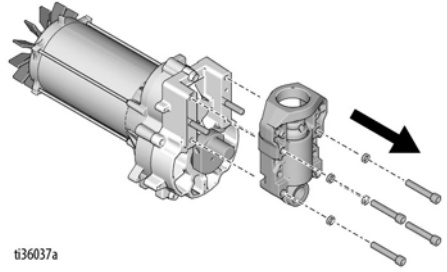

ti36037a

NOTE: Do not drop gear cluster when removing drive housing. Gear cluster may stay engaged in motor front end bell or drive housing.

6. Remove three screws and drive housing.

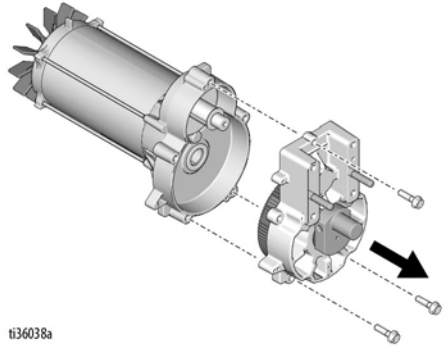

ti36038a

7. Remove screw and fan.

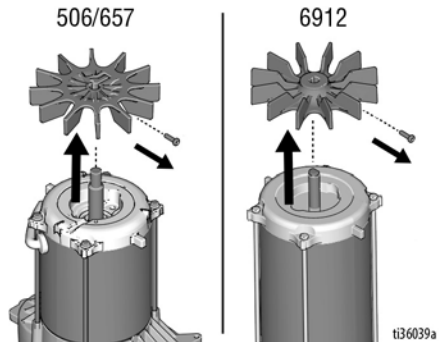

ti36039a

Motor Installation

NOTICE

When installing motor, carefully align gears to avoid damaging mating parts.

1. Install drive housing with three screws.

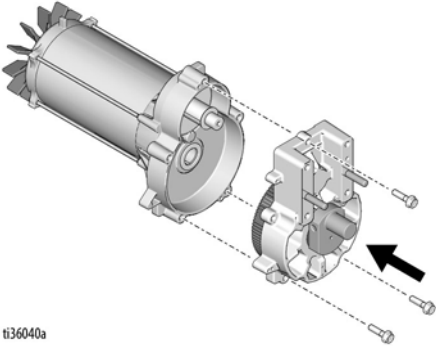

2. Install bearing housing with four screws and washers. Torque to 25 - 30 ft-lbs (33.9 - 40.67 N·m).

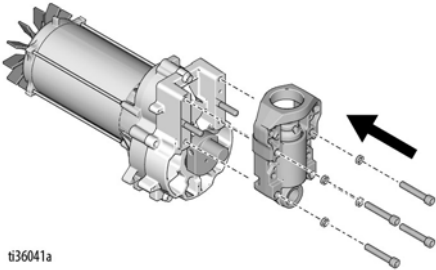

3. Install motor with two screws. Torque to 200 - 220 in-lbs (22.6 - 24.9 N·m).

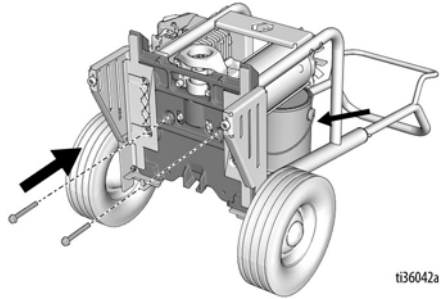

4. Install fan with screw. Torque 11 - 13 in-lb (1.24 - 1.46 N·m).

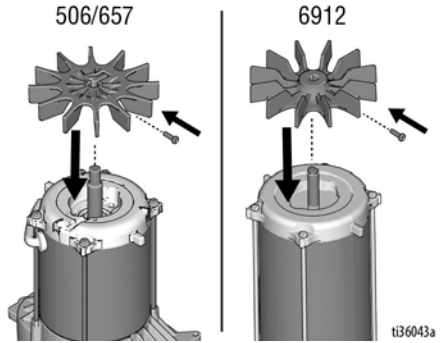

5. Install pump. See **Pump Installation**, page 56.

Recycling and Disposal at End of Life

At the end of the product's useful life, dismantle and recycle it in a responsible manner.

Preparation:

- Perform the **Pressure Relief Procedure**.
- Drain and dispose of fluids according to applicable regulations. Refer to the material manufacturer's Safety Data Sheet.

Dismantle and recycle:

- Remove motors, circuit boards, LCDs (liquid crystal displays), and other electronic components. Recycle according to applicable regulations.
- Do not dispose of electronic components with household or commercial waste.



- Deliver remaining product to a recycling facility.

Parts - Hopper Frame

Parts - Hopper Frame

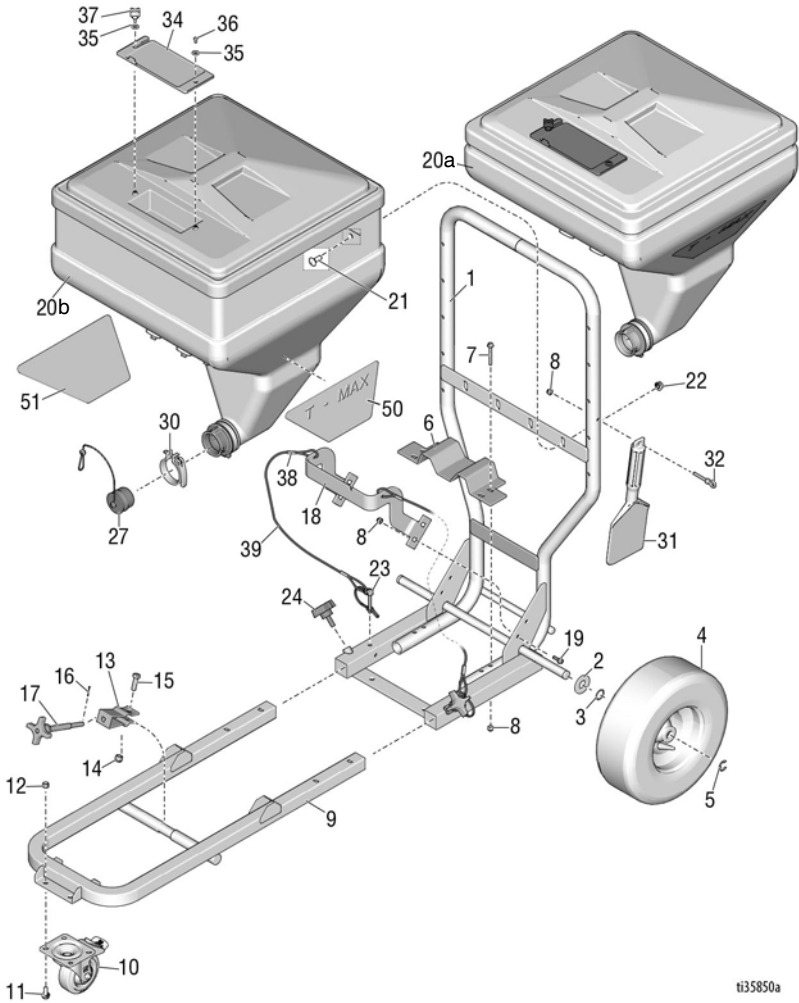

t135850a

Parts List - Frame

Ref. Part	Description	Qty	Ref. Part	Description	Qty		
1	19A673	FRAME, hopper, Tmax	1	18	19A674	BRACKET, guide, hopper	1
2	156306	WASHER, flat	2	19	113796	SCREW, flanged, hex hd	4
3	116038	WASHER, wave spring	2	20		HOPPER, material	
4	119509	WHEEL, pneumatic	2	20a	25E541	17 gallon	1
5	120211	RING, retaining, e-ring	2	20b	25E542	25 gallon	1
6	19A675	BRACKET, support, hopper	1	21	404533	BOLT, carriage	4
7	129335	SCREW, hex, serrated, 1/4-20 x 2.00	4	22	112958	NUT, hex, flanged 3/8 -16	4
8	102040	NUT, lock, hex	9	23	121313	PIN, locking, 1-4"	2
9	25E625	FRAME, mounting, power module	1	24	111145	KNOB, pronged	2
10	17N602	CASTER, swivel	1	27	15D306	PLUG, adapter, hopper	1
11	110963	SCREW, cap, hex hd	4	30	234188	CLAMP, quick release	1
12	111040	NUT, lock , insert, nylock 5/16	4	31	19A646	TOOL, scraper	1
13	15C797	BRACKET, swivel	1	32	130878	BOLT, hook, 1/4-20 x 1-5/8 thd	1
14	101566	NUT, lock	1	34	15D561	COVER, tool tray	1
15	100004	SCREW, cap, hex hd	1	35	115814	WASHER, flat, sst	2
16	104430	PIN, cotter	1	36	551787	SCREW, cap	1
17	15C799	ROD, clamp	1	37	19A714	KNOB, stuf, #10-32 x .44	1
				38	120481	SLEEVE, oval	4
				39	120483	CABLE	2.5
				50	19A748	LABEL, brand, Tmax, left	1
				51	19A749	LABEL, brand, Tmax, right	1

Parts - Power Module 506/657

Parts - Power Module 506/657

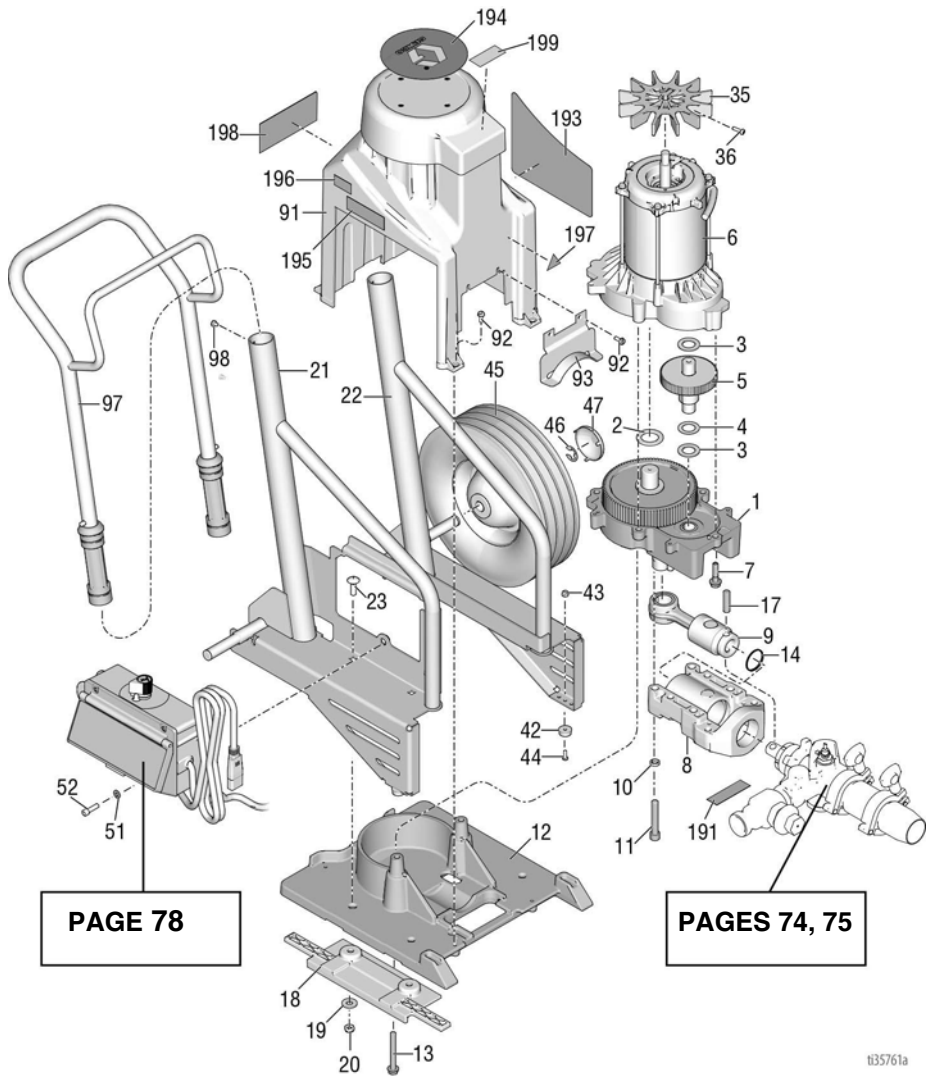

Parts - Power Module 506/657

Parts List - Power Module 506/657

Ref.	Part	Description	Qty	Ref.	Part	Description	Qty
1	287234	HOUSING, drive, Tmax 506	1	42	19A713	BUMPER, rubber	1
	287235	HOUSING, drive, Tmax 657		43	115483	NUT, lock	2
2	116192	WASHER, thrust	1	44	103374	SCREW, mach, rhd	2
3	114672	WASHER, thrust	2	45	106062	WHEEL, semi- pneumatic	2
4	114699	WASHER, thrust	1	46	101242	RING, retaining	2
5	243951	GEAR, cobination	1	47	104811	CAP, hub	2
6	289570	MOTOR	1	51	100016	WASHER, lock	2
7	15C753	SCREW, mach, hex wash hd	3	52	110298	SCREW, cap, sch	2
8	240724	HOUSING, bearing	1	91	15R741	SHIELD, Tmax, painted	1
9	287395	ROD, connecting	1	92	118444	SCREW, mach, slot hex wash hd	6
10	106115	WASHER, lock	4	93	15T629	SHIELD, pump rod	1
11	114666	SCREW, cap, socket head	4	97	287489	HANDLE, assy, hi cart	1
12	19A690	BASE, drive module, machined	1	98	109032	SCREW, mach, pnh	2
13	120981	SCREW, mach, hex washer hd	2	191	187437	LABEL, torque	1
14	119778	SPRING, retaining	1	193	19A814	LABEL, brand, Tmax 506	1
17	15F856	PIN, pump	1		19A815	LABEL, brand, Tmax 657	1
18	19A585	GUIDE, power module	2	194	15U014	LABEL, brand, Tmax cap	1
19	100023	WASHER, flat	4	195	17P925	LABEL, A+ Service	1
20	112746	NUT, lock, nylon	4	196	15Y118	LABEL, made in USA	1
21	19A669	FRAME, right, Tmax, painted	1	197▲	15H108	LABEL, safety, warning, pinch	1
22	19A670	FRAME, left, Tmax, painted	1	198▲	17Z485	LABEL, safety	1
23	107129	BOLT, round head	4	199▲	16C681	LABEL, notice	1
35	15D088	FAN, motor	1				
36	115477	SCREW, mach, torx pan hd	1				

▲ Replacement safety labels, tags, and cards are available at no cost.

Parts - Power Module 6912

Parts - Power Module 6912

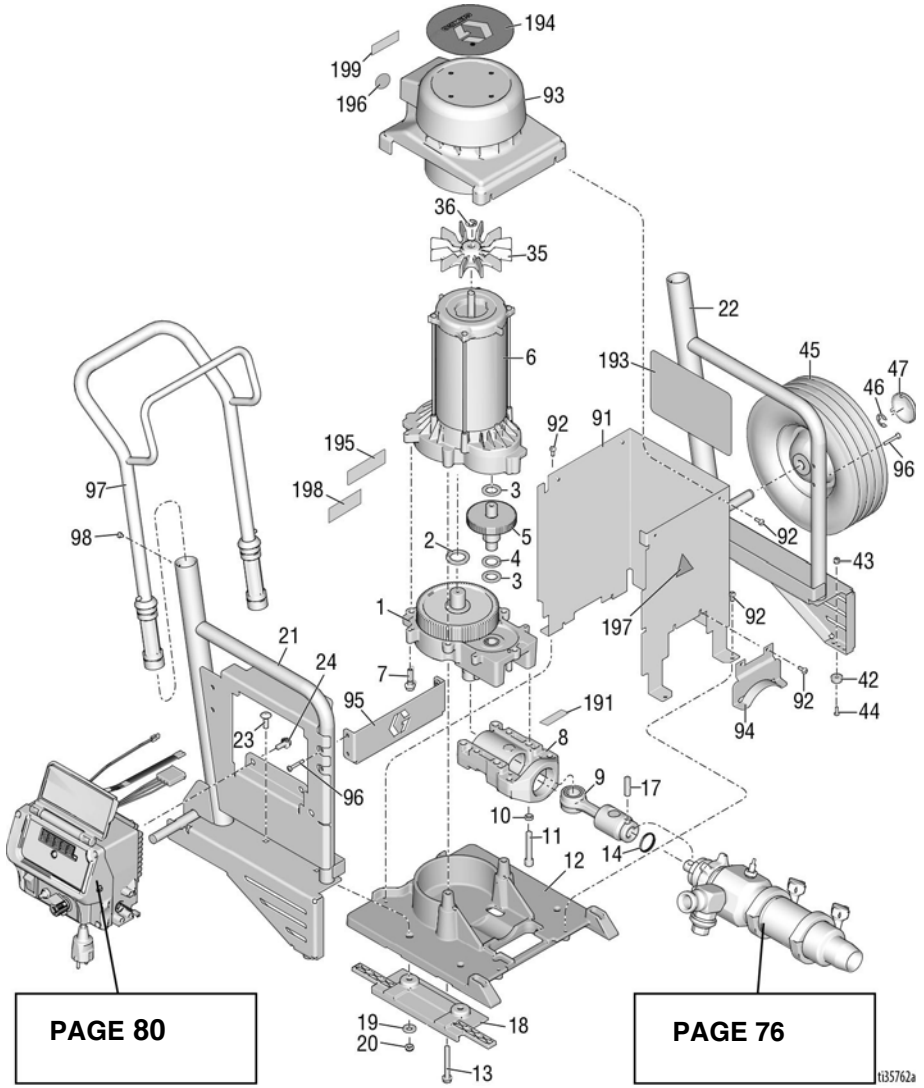

PAGE 80

PAGE 76

1135762a

Parts - Power Module 6912

Parts List - Power Module 6912

Ref.	Part	Description	Qty	Ref.	Part	Description	Qty
1	24M008	HOUSING, drive	1	43	115483	NUT, lock	2
2	116192	WASHER, thrust	1	44	103374	SCREW, mach	2
3	114672	WASHER, thrust	2	45	106062	WHEEL, semi-pneumatic	2
4	114699	WASHER, thrust	1	46	101242	RING, retaining	2
5	243951	GEAR, combination	1	47	104811	CAP, hub	2
6	25P037	KIT, repair, motor	1	49	19A738	GROMMET	1
7	15C753	SCREW, mach, hex wash hd	3	91	19A676	COVER, motor, Tmax, painted	1
8	245795	HOUSING, bearing	1	92	118444	SCREW, mach, slot hex wash hd	10
9	287395	ROD, connecting	1	93	19A666	SHIELD, assy w/ shroud, painted	1
10	106115	WASHER, lock	4	94	15T629	SHIELD, pump rod	1
11	114666	SCREW, cap, socket, head	4	95	19A715	BRACE, front	1
12	19A690	BASE, drive module	1	96	126687	SCREW, mach, pnh	4
13	120981	SCREW, mach, hex washer hd	2	97	287489	HANDLE, assy, hi cart	1
14	17Z347	SPRING, retaining	1	98	109032	SCREW, mach, pnh	4
17	15F856	PIN, pump	1	191	187437	LABEL, torque	1
18	19A585	GUIDE, power module	2	193	19A750	LABEL, 6912 brand	1
19	100023	WASHER, flat	4	194	15U014	LABEL, cap brand	1
20	112746	NUT, lock, nylon	4	195	17P925	LABEL, A+ service	1
21	19A671	FRAME, right, Tmax, painted	1	196	15Y118	LABEL, made in USA	1
22	19A672	FRAME, left, Tmax, painted	1	197▲	15H108	LABEL, pinch	1
23	107129	BOLT, round head	4	198▲	16G596	LABEL, safety	1
24	117791	SCREW, cap	2	199▲	16C681	LABEL, notice	1
35*	15D088	FAN, motor	1				
36*	115U77	SCREW	1				
42	19A713	BUMPER, rubber	2				

* Included in Motor Repair Kit 25P037

▲ Replacement safety labels, tags, and cards are available at no cost.

Parts - Pump 289555 (506)

Parts - Pump 289555 (506)

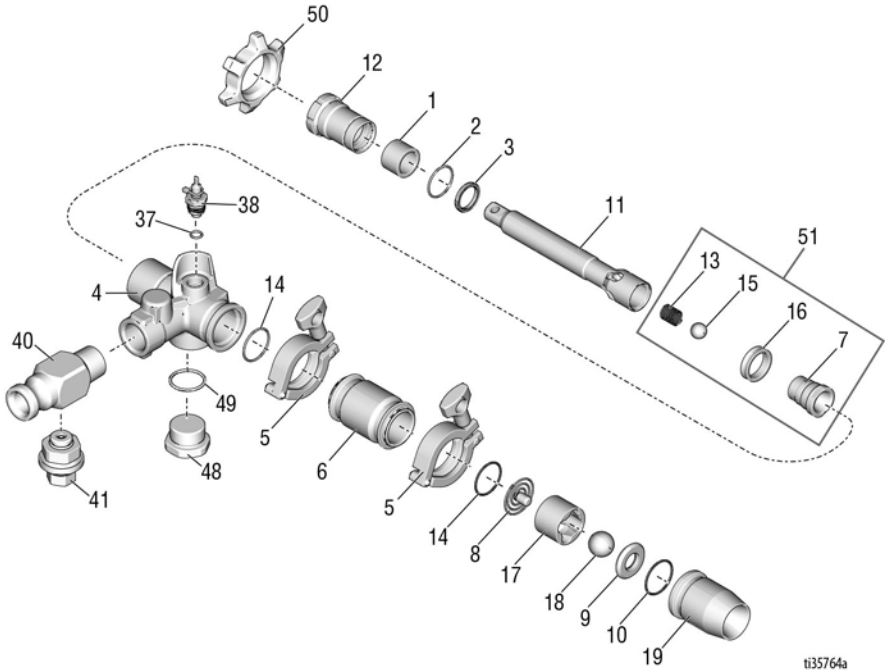

ti35764a

Parts List - Pump

Ref.	Part	Description	Qty	Ref.	Part	Description	Qty
1	15D117	TUBE, fiber, pump	1	13	501095	SPRING, ball check	1
2	107185	PACKING, o-ring	1	14	121588	O-RING	2
3	118597	PACKING, u-cup	1	15	101822	BALL, bearing	1
4	15R739	HOUSING, outlet, machining	1	16	15D116	SEAL, piston	1
5	118598	CLAMP, sanitary, 1.5 in.	2	17	15D115	GUIDE, ball	1
6	15R740	CYLINDER, pump	1	18	107167	BALL, sst	1
7	248232	VALVE, piston	1	19	248769	HOUSING, intake	1
	248530	KIT, repair, seal, piston, includes 7, 13, 15, 16	1	37	111457	O-RING	1
8	248162	SPRING, Intake ball	1	38	289672	TRANSDUCER	1
9	193395	SEAT, carbide	1	40	17Z238	OUTLET	1
10	107098	PACKING, o-ring	1	41	17Y930	RELIEF, pressure	1
11	15R620	ROD, pump	1	48	17Z345	PLUG	1
12	15D112	NUT, packing	1	49	121429	O-RING	1
				50	193031	NUT, retaining	1
				51	248530	KIT, valve, piston <i>includes 7, 13, 15, 16</i>	1

Parts - Pump 289556 (657)

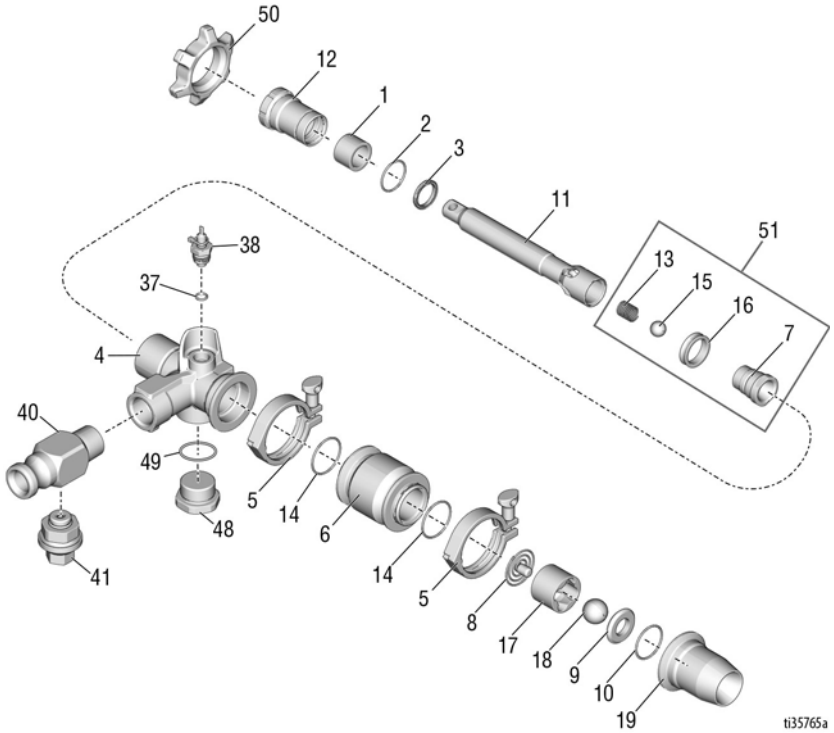

Parts List - Pump

Ref.	Part	Description	Qty	Ref.	Part	Description	Qty
1	15D117	TUBE, fiber, pump	1	13	501095	SPRING, ball check	1
2	107185	PACKING, o-ring	1	14	121587	O-RING	2
3	118597	PACKING, u-cup	1	15	101822	BALL, bearing	1
4	15R621	HOUSING, outlet, machining	1	16	15D116	SEAL, piston	1
5	500984	CLAMP	2	17	15D115	GUIDE, ball	1
6	15R619	CYLINDER, pump	1	18	107167	BALL, sst	1
7	248232	VALVE, piston	1	19	289941	HOUSING, intake	1
	248530	KIT, repair, seal, piston, includes 7, 13, 15, 16	1	37	111457	O-RING	1
8	248162	SPRING, Intake ball	1	38	289672	TRANSDUCER	1
9	193395	SEAT, carbide	1	40	17Z238	OUTLET	1
10	107098	PACKING, o-ring	1	41	17Y930	RELIEF, pressure	1
11	15R620	ROD, pump	1	48	17Z345	PLUG	1
12	15D112	NUT, packing	1	49	121429	O-RING	1
	248529	KIT, repair, throat seal includes 1, 2, 3, 12	1	50	193031	NUT, retaining	1
				51	248530	KIT, valve, piston includes 7, 13, 15, 16	1

Parts - Pump 25E668 (6912)

Parts - Pump 25E668 (6912)

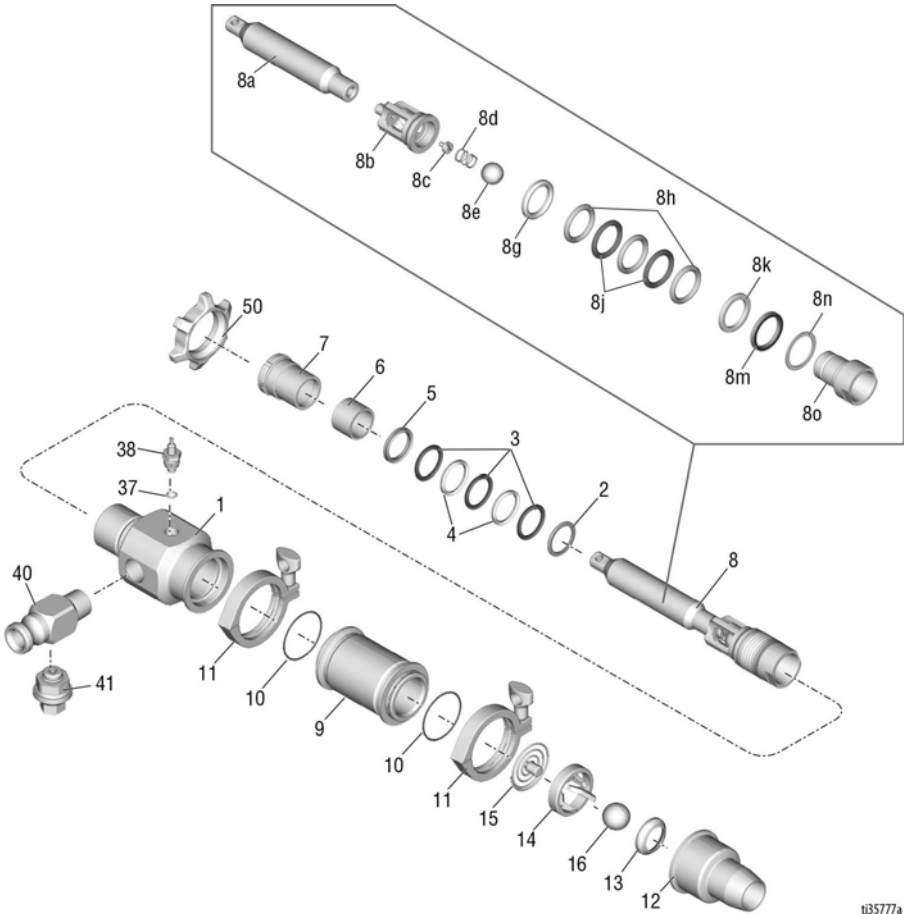

t135777a

Parts - Pump 25E668 (6912)

Parts List - Pump 25E668 (6912)

Ref.	Part	Description	Qty	Ref.	Part	Description	Qty
1	19A610	HOUSING, outlet, machining		10†	130792	O-RING	2
2†	187939	GLAND, male	1	11	620223	CLAMP	2
3†	187071	PACKING, vee	3	12	17Z241	HOUSING, intake ball	1
4†	188560	PACKING	2	13	235962	SEAL, foot valve	1
5†	187070	GLAND, female	1	14	19A692	GUIDE, ball, inlet	1
6†	19A625	WIPER, fiber, pump rod	1	15	25E679	SPRING, intake, assy	1
7	19A685	NUT, packing	1	16	102973	BALL, metallic	1
8	25E669	ROD, pump	1	37	111457	O-RING	1
8a	19A686	ROD, pump	1	38	289672	KIT, includes 37	1
8b	19A689	HOUSING, piston pump	1	40	17Z238	OUTLET	1
8c	19A691	BALL, stop	1	41	17Y930	RELIEF, pressure	1
8d	130862	SPRING, compression	1	50	193394	NUT	1
8e	107167	BALL, sst	1		17Z556	BALL, sst, inlet & outlet	
8g†	188432	GLAND, packing, male	1		17Z648	BALL, hard, white, inlet & outlet	
8h†	187072	PACKING	3		17Z640	BALL, hard, black, inlet & outlet	
8j†	188561	PACKING, throat	2		17Z231	BALL, rubber, inlet	
8k†	188433	GLAND, packing, female	1		248515	BALL, cleaning	
8m†	188558	SEAL, u-cup	1				
8n†	188627	WASHER, back-up	1				
8o	17Z242	VALVE, piston, assy	1				
9	19A609	CYLINDER, pump	1				

† included in Pump Repack Kit 17Z641

Parts - Control Box 506/657

Parts - Control Box 506/657

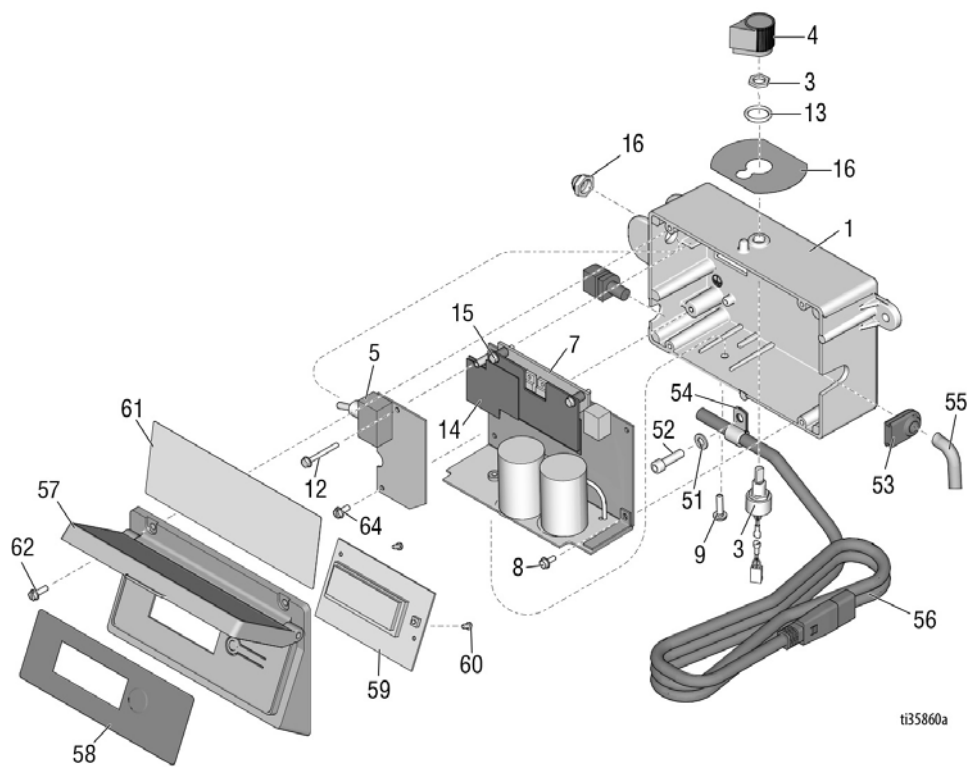

ti35860a

Parts - Control Box 506/657

Parts List - Control Box 506/657

Ref.	Part	Description	Qty	Ref.	Part	Description	Qty
1	277228	BOX, control	1	53	15B120	GROMMET, transducer	1
2	15G562	BUSHING, control box	1	54	121453	CLAMP, wire	1
3	256219	POTENTIOMETER	1	55	15T342	CONDUIT, corrugated	1
4	116167	KNOB, potentiometer	1	56a	15B469	CORD, st, UK	1
5	249451	FILTER, board	1	56b	158470	CORD, st, CE	1
6	195428	BOOT, toggle	1	57	287789	COVER, control	1
7	24T249	BOARD, control, assy	1	58	15G861	LABEL, smart control	1
8	120405	SCREW, mach, hex	3			LCD display	
		washer hd		59	245931	DISPLAY, LCD	1
9	120165	SCREW, mach, phillips	1	60	115522	SCREW, mach, pnh	1
12	120406	SCREW, mach, hex	1	61	15K401	LABEL, smartcontrol /	1
		washer hd				international	
13	158674	O-RING	1	62	117501	SCREW, mach, slot hex	1
14	24X149	PLATE, heat sink	1			wash hd	
15	128038	SCREW, mach, hex,	2	63	102478	STRAP, tie wiring	1
		washer hd		64	115498	SCREW, mach, slot hex	1
16	17F671	LABEL, control	1			wash hd	
51	100016	WASHER, lock	1	192	15U037	LABEL, control	1
52	110298	SCREW, CAP, sch	1				

Parts - Control Box 6912

Parts - Control Box 6912

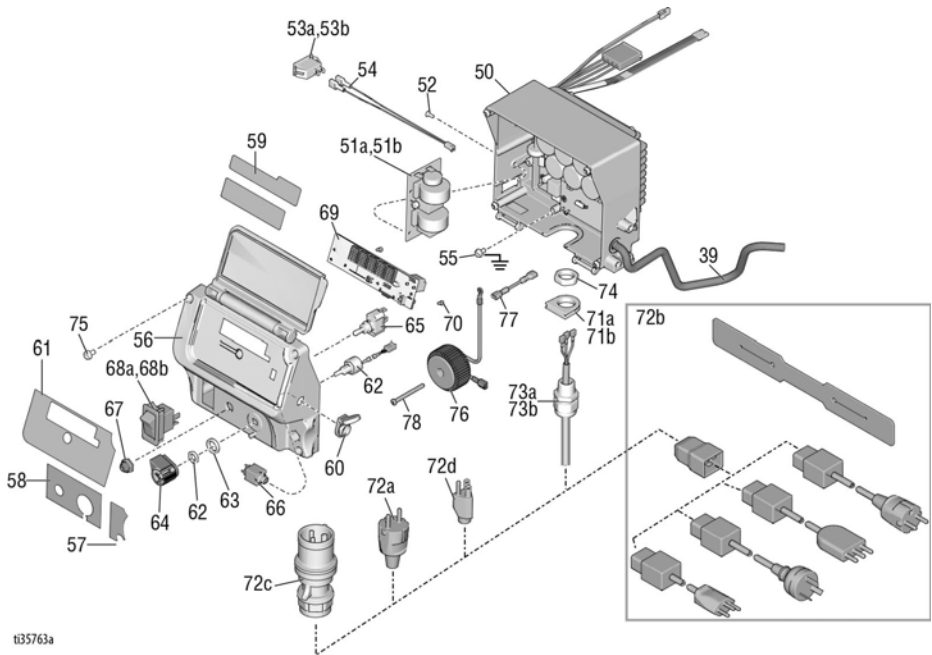

t35763a

Parts List - Control Box

Ref.	Part	Description	Qty	Ref.	Part	Description	Qty
	277228	BOX, control	1				
	15G562	BUSHING, control box	1	62	17D888	POTENTIOMETER	1
	287913	FILTER, board	1	63	15C973	GASKET	1
	120405	SCREW, mach, hex	5	64	116167	KNOB, potentiometer	1
		washer hd		65	130863	SWITCH, toggle	1
	120165	SCREW, mach, phillips	1	66	19A719	HARNESS	1
	120406	SCREW, mach, hex	1	67	195428	BOOT, toggle	1
		washer hd		68a	15D527	SWITCH, rocker, 240V	1
	158674	O-RING	1	68b	15C979	SWITCH, rocker, 120V	1
39	15T342	CONDUIT	1	69	24U123	BOARD	1
50	25E760	CONTROL, board, 240V	1	70	114391	SCREW	2
51a	24U823	BOARD, EU	1	71a	16T544	ADAPTER, EU	1
51b	24R597	BOARD, UK	1	71b	16T546	ADAPTER, UK	1
52	119288	SCREW	2	72	16M834	CORD	1
53a	126029	SWITCH, rocker, 240V	1	73a	117745	BUSHING, strain relief, EU	1
53b	120059	SWITCH, rocker, 120V	1	73b	116171	BUSHING, strain relief, US	1
54	15G935	CONNECTOR	1	74	117625	NUT, locking	1
55	114391	SCREW, grounding	1	75*	16V095	SCREW	4
56*	19A642	COVER	1	76	15H063	COIL, filter, US	1
57*	16Y788	LABEL	1	77	16T541	JUMPER, wire, US	1
58*	17Z406	LABEL	1	78	16U215	SCREW, phillips pan hd, US	1
59*	16X797	LABEL	1				
60	120761	COVER, jack	1				
61*	16X796	LABEL	1				

* Included in Repair Kit 19A902

Wiring Diagrams

506/657

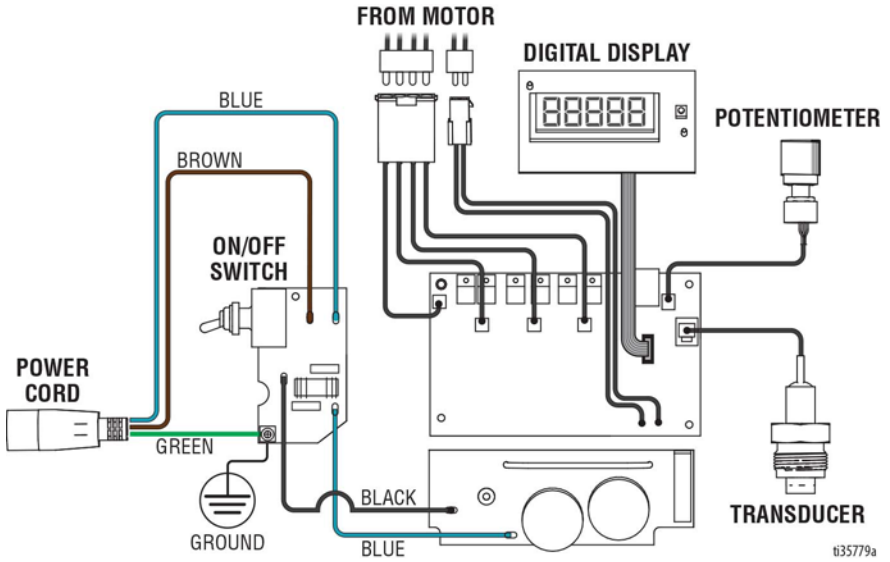

t35779a

Wiring Diagrams

6912 - US

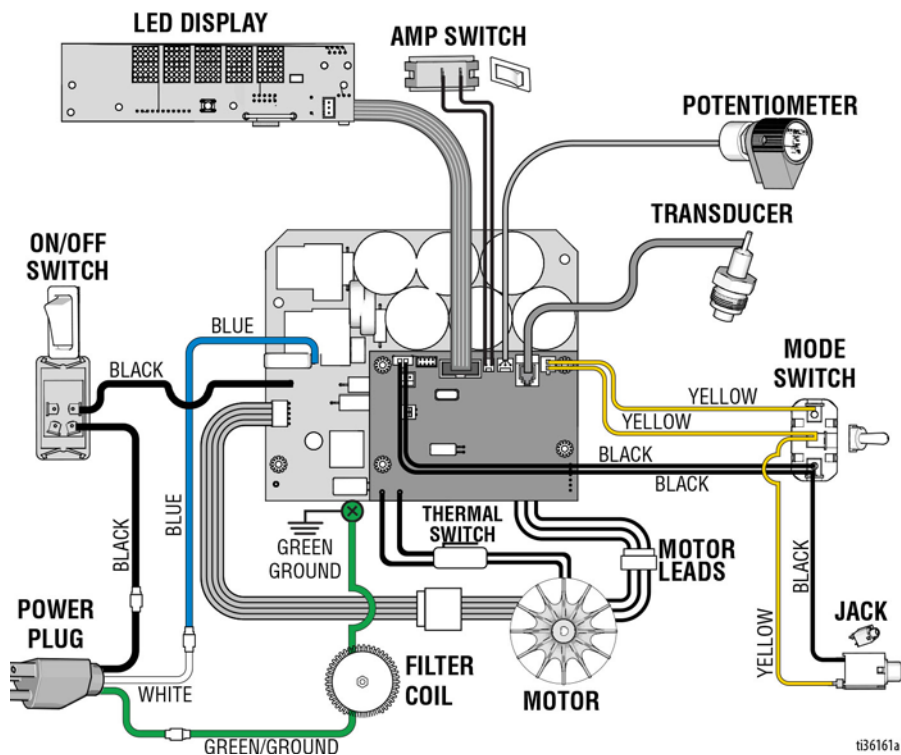

6912 - UK

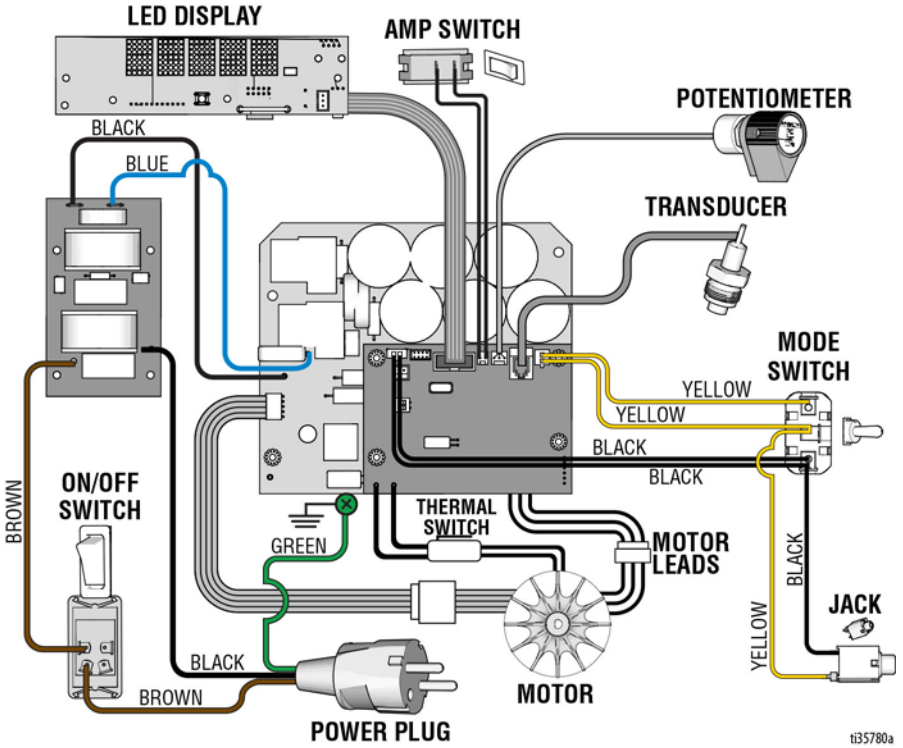

t135780a

Technical Specifications

Technical Specifications

T-Max 506		
	US	Metric
Power requirements	100-120 Vac	220-240 Vac
	50/60 Hz, 13A	50/60 Hz, 8A
Motor.	1.2 HP	900 W
Maximum fluid working pressure	730 psi	5.0 MPa, 50 bar
Maximum air working pressure . .	250 psi	1.7 MPa, 17 bar
Generator required	7 kW	
Hopper capacity		
Maximum	20 gallons	76 liters
Operating	17 gallons	64 liters
Maximum delivery with texture material.	1.2 to 1.7 gpm	4,5 to 6,4 lpm
Fluid outlet size.	1.0 in. (m) cam and groove	
Dimensions		
Length (with handle)	42 to 44 in.	107 cm to 112 cm
Width.	23 in.	58 cm
Height	46 in.	117 cm
Weight		
Module only	88 lb	40 kg
Module & hopper	156 lb	71 kg
Noise (dBa)		
Maximum sound pressure	82.4	
Maximum power level.	97.0	
<i>Sound pressure measured 3.28 feet (1 meter) from equipment.</i>		
<i>Sound power measured per ISO-3744.</i>		
Wetted Parts		
Buna-N, aluminum, brass, polyethylene, neoprene, stainless steel, chrome-plated carbon steel, nickel-plated carbon steel, viton, nickel-plated iron, wool felt, tungsten carbide, PTFE		

Technical Specifications

T-Max 657		
	US	Metric
Power requirements	100-120 Vac	220-240 Vac
	50/60 Hz, 13A	50/60 Hz, 8A
Motor	1.2 HP	900 W
Maximum fluid working pressure.	940 psi	6.5 MPa, 17 bar
Maximum air working pressure . .	250 psi	1.7 MPa, 17 bar
Generator required	7 kW	
Dimensions		
Maximum	28 gallons	106 liters
Operating	25 gallons	95 liters
Maximum delivery with texture material	1.4 to 1.9 gpm	5,3 to 7,2 lpm
Fluid outlet size	1.0 in. (m) cam and groove	
Dimensions		
Length (with handle)	46 to 48 in.	117 cm to 122 cm
Width	23 in.	58 cm
Height	46 in.	117 cm
Weight		
Module only	91 lb	41 kg
Module & hopper.	160 lb	73 kg
Noise (dBa)		
Maximum sound pressure.	82.4	
Maximum power level	97.0	
<i>Sound pressure measured 3.28 feet (1 meter) from equipment.</i>		
<i>Sound power measured per ISO-3744.</i>		
Wetted Parts		
Buna-N, aluminum, brass, polyethylene, neoprene, stainless steel, chrome-plated carbon steel, nickel-plated carbon steel, viton, nickel-plated iron, wool felt, tungsten carbide, PTFE		

Technical Specifications

T-Max 6912		
	US	Metric
Power requirements	100-120 Vac	220-240 Vac
	50/60 Hz, 15/20A	50/60 Hz, 10/16A
Motor.	2.5 HP	1864 W
Maximum fluid working pressure	1000 psi	6.9 MPa, 69 bar
Maximum air working pressure . .	250 psi	1.7 MPa, 17 bar
Generator required	7 kW	
Dimensions		
Maximum	28 gallons	106 liters
Operating	25 gallons	95 liters
Maximum delivery with texture material.	2.4 to 3.2 gpm	9,1 to 12,1 lpm
Fluid outlet size.	1.0 in. (m) cam and groove	
Dimensions		
Length (with handle)	46 to 48 in.	117 cm to 122 cm
Width.	23 in.	58 cm
Height	46 in.	117 cm
Weight		
Module only	121 lb	55 kg
Module & hopper	190 lb	86 kg
Noise (dBa)		
Maximum sound pressure	80.7	
Maximum power level.	95.8	
<i>Sound pressure measured 3.28 feet (1 meter) from equipment.</i>		
<i>Sound power measured per ISO-3744.</i>		
Wetted Parts		
Buna-N, aluminum, brass, polyethylene, neoprene, stainless steel, chrome-plated carbon steel, nickel-plated carbon steel, viton, nickel-plated iron, wool felt, tungsten carbide, PTFE		

CALIFORNIA PROPOSITION 65



WARNING: This product can expose you to chemicals known to the State of California to cause cancer and birth defects or other reproductive harm. For more information go to www.P65Warnings.ca.gov.

Graco Standard Warranty

Graco warrants all equipment referenced in this document which is manufactured by Graco and bearing its name to be free from defects in material and workmanship on the date of sale to the original purchaser for use. With the exception of any special, extended, or limited warranty published by Graco, Graco will, for a period of twelve months from the date of sale, repair or replace any part of the equipment determined by Graco to be defective. This warranty applies only when the equipment is installed, operated and maintained in accordance with Graco's written recommendations.

This warranty does not cover, and Graco shall not be liable for general wear and tear, or any malfunction, damage or wear caused by faulty installation, misapplication, abrasion, corrosion, inadequate or improper maintenance, negligence, accident, tampering, or substitution of non-Graco component parts. Nor shall Graco be liable for malfunction, damage or wear caused by the incompatibility of Graco equipment with structures, accessories, equipment or materials not supplied by Graco, or the improper design, manufacture, installation, operation or maintenance of structures, accessories, equipment or materials not supplied by Graco.

This warranty is conditioned upon the prepaid return of the equipment claimed to be defective to an authorized Graco distributor for verification of the claimed defect. If the claimed defect is verified, Graco will repair or replace free of charge any defective parts. The equipment will be returned to the original purchaser transportation prepaid. If inspection of the equipment does not disclose any defect in material or workmanship, repairs will be made at a reasonable charge, which charges may include the costs of parts, labor, and transportation.

THIS WARRANTY IS EXCLUSIVE, AND IS IN LIEU OF ANY OTHER WARRANTIES, EXPRESS OR IMPLIED, INCLUDING BUT NOT LIMITED TO WARRANTY OF MERCHANTABILITY OR WARRANTY OF FITNESS FOR A PARTICULAR PURPOSE.

Graco's sole obligation and buyer's sole remedy for any breach of warranty shall be as set forth above. The buyer agrees that no other remedy (including, but not limited to, incidental or consequential damages for lost profits, lost sales, injury to person or property, or any other incidental or consequential loss) shall be available. Any action for breach of warranty must be brought within two (2) years of the date of sale.

GRACO MAKES NO WARRANTY, AND DISCLAIMS ALL IMPLIED WARRANTIES OF MERCHANTABILITY AND FITNESS FOR A PARTICULAR PURPOSE, IN CONNECTION WITH ACCESSORIES, EQUIPMENT, MATERIALS OR COMPONENTS SOLD BUT NOT MANUFACTURED BY GRACO. These items sold, but not manufactured by Graco (such as electric motors, switches, hose, etc.), are subject to the warranty, if any, of their manufacturer. Graco will provide purchaser with reasonable assistance in making any claim for breach of these warranties.

In no event will Graco be liable for indirect, incidental, special or consequential damages resulting from Graco supplying equipment hereunder, or the furnishing, performance, or use of any products or other goods sold hereto, whether due to a breach of contract, breach of warranty, the negligence of Graco, or otherwise.

FOR GRACO CANADA CUSTOMERS

The Parties acknowledge that they have required that the present document, as well as all documents, notices and legal proceedings entered into, given or instituted pursuant hereto or relating directly or indirectly hereto, be drawn up in English. Les parties reconnaissent avoir convenu que la rédaction du présente document sera en Anglais, ainsi que tous documents, avis et procédures judiciaires exécutés, donnés ou intentés, à la suite de ou en rapport, directement ou indirectement, avec les procédures concernées.

Graco Information

For the latest information about Graco products, visit www.graco.com.

For patent information, see www.graco.com/patents.

TO PLACE AN ORDER, contact your Graco distributor or call 1-800-690-2894 to identify the nearest distributor.

All written and visual data contained in this document reflects the latest product information available at the time of publication.

Graco reserves the right to make changes at any time without notice.

Original instructions. This manual contains English. MM 3A6748

Graco Headquarters: Minneapolis
International Offices: Belgium, China, Japan, Korea

GRACO INC. AND SUBSIDIARIES • P.O. BOX 1441 • MINNEAPOLIS MN 55440-1441 • USA

Copyright 2019, Graco Inc. All Graco manufacturing locations are registered to ISO 9001.

www.graco.com
Revision B, June 2019